

Frequency Inverter

CFW-11

User's Manual

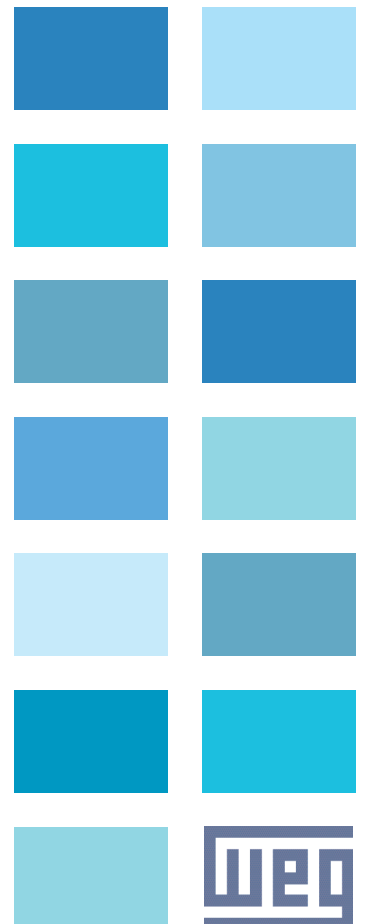

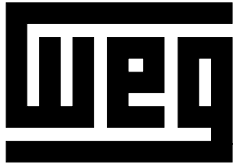

CFW-11 VECTRUE INVERTER

FREQUENCY INVERTER MANUAL

Series: CFW-11

Language: English

Document: 10000280997 / 04

Models: 142...211 A / 220...230 V

105...211 A / 380...480 V

Summary of Revisions

Version	Review	Description
-	R01	First edition
-	R02	Setting in Table 3.6 on page 3-23
-	R03	General revision
-	R04	General revision

1	SAFETY INSTRUCTIONS	1-1
1.1	SAFETY WARNINGS IN THE MANUAL	1-1
1.2	SAFETY WARNINGS IN THE PRODUCT	1-1
1.3	PRELIMINARY RECOMMENDATIONS	1-2
2	GENERAL INSTRUCTIONS	2-1
2.1	ABOUT THE MANUAL	2-1
2.2	TERMS AND DEFINITIONS	2-2
2.3	ABOUT THE CFW-11	2-4
2.4	IDENTIFICATION LABELS FOR THE CFW-11	2-7
2.5	RECEIVING AND STORAGE	2-10
3	INSTALLATION AND CONNECTION	3-1
3.1	MECHANICAL INSTALLATION	3-1
3.1.1	Installation Environment	3-1
3.1.2	Mounting Considerations	3-2
3.1.3	Cabinet Mounting	3-5
3.1.4	Installation of the Inverter Hoisting Eyes	3-6
3.1.5	Installation of the Inverter with Nema1 Kit (Option, CFW11....T... ON1...) on a Wall	3-7
3.1.6	Access to the Control and Power Terminal Strips	3-7
3.1.7	Removal of the Cable Passage Plate	3-9
3.1.8	HMI Installation at the Cabinet Door or Command Panel (Remote HMI)	3-10
3.2	ELECTRICAL INSTALLATION	3-10
3.2.1	Identification of the Power and Grounding Terminals	3-11
3.2.2	Power/Grounding Wiring and Fuses	3-11
3.2.3	Power Connections	3-16
3.2.3.1	Input Connections	3-16
3.2.3.2	AC Power Supply Considerations	3-17
3.2.3.2.1	IT Networks	3-17
3.2.3.2.2	Command Fuses of Pre-Charge Circuit	3-19
3.2.3.3	Dynamic Braking	3-19
3.2.3.2.1	Sizing the Braking Resistor	3-20
3.2.3.2.2	Installation of the Braking Resistor	3-21
3.2.3.4	Output Connections	3-22
3.2.4	Grounding Connections	3-24
3.2.5	Control Connections	3-25
3.2.6	Typical Control Connections	3-31
3.3	SAFETY STOP FUNCTION	3-34
3.3.1	Installation	3-35
3.3.2	Operation	3-36
3.3.2.1	Truth Table	3-36
3.3.2.2	State of Inverter, Fault and Alarm Related to Safety Stop Function	3-36
3.3.2.3	STO Status Indication	3-36
3.3.2.4	Periodic Test	3-37

- 3.3.3 Examples of Wiring Diagrams of Inverter Control Signal 3-38
- 3.3.4 Technical Specifications 3-39
 - 3.3.4.1 Electrical Control Characteristics 3-39
 - 3.3.4.2 Operational Safety Characteristics..... 3-39
- 3.4 INSTALLATION ACCORDING TO THE EUROPEAN DIRECTIVE OF ELECTROMAGNETIC COMPATIBILITY 3-40
 - 3.4.1 Conformal Installation 3-40
 - 3.4.2 Standard Definitions 3-41
 - 3.4.3 Emission and Immunity Levels..... 3-42

- 4 HMI 4-1
 - 4.1 INTEGRAL KEYPAD - HMI-CFW11 4-1
 - 4.2 PARAMETERS ORGANIZATION..... 4-4

- 5 FIRST TIME POWER-UP AND START-UP 5-1
 - 5.1 PREPARE FOR START-UP 5-1
 - 5.2 START-UP 5-2
 - 5.2.1 Password Setting in P0000 5-2
 - 5.2.2 Oriented Start-Up..... 5-3
 - 5.2.3 Setting Basic Application Parameters..... 5-5
 - 5.3 SETTING DATE AND TIME 5-8
 - 5.4 BLOCKING PARAMETERS MODIFICATION..... 5-9
 - 5.5 HOW TO CONNECT A PC..... 5-9
 - 5.6 FLASH MEMORY MODULE..... 5-10

- 6 TROUBLESHOOTING AND MAINTENANCE 6-1
 - 6.1 OPERATION OF THE FAULTS AND ALARMS..... 6-1
 - 6.2 FAULTS, ALARMS AND POSSIBLE CAUSES..... 6-2
 - 6.3 SOLUTIONS FOR THE MOST FREQUENT PROBLEMS 6-8
 - 6.4 INFORMATION FOR CONTACTING TECHNICAL SUPPORT..... 6-9
 - 6.5 PREVENTIVE MAINTENANCE 6-9
 - 6.5.1 Cleaning Instructions 6-10

- 7 OPTION KITS AND ACCESSORIES 7-1
 - 7.1 OPTION KITS 7-1
 - 7.1.1 Nema1 Protection Degree 7-1
 - 7.1.2 Degree of Protection IP55..... 7-1
 - 7.1.3 Safety Stop Function 7-1
 - 7.1.4 Braking IGBT..... 7-1
 - 7.1.5 24 Vdc External Control Power Supply 7-2
 - 7.2 ACCESSORIES 7-3

8 TECHNICAL SPECIFICATIONS..... 8-1
8.1 POWER DATA..... 8-1
8.2 ELECTRICAL/GENERAL SPECIFICATIONS..... 8-6
8.3 CODES AND STANDARDS 8-7
8.4 CERTIFICATIONS..... 8-8
8.5 MECHANICAL DATA..... 8-9
8.6 NEMA1 KIT 8-11

1 SAFETY INSTRUCTIONS

This manual provides information for the proper installation and operation of the CFW-11 frequency inverter.

Only trained and qualified personnel should attempt to install, start-up, and troubleshoot this type of equipment.





1.1 SAFETY WARNINGS IN THE MANUAL

The following safety warnings are used in this manual:

 **DANGER!**
Failure to follow the recommended procedures listed in this warning may result in death, serious injury, and equipment damage.

 **DANGER!**
Les procédures concernées par cet avertissement sont destinées à protéger l'utilisateur contre des dangers mortels, des blessures et des détériorations matérielles importantes.

 **ATTENTION!**
Failure to follow the recommended procedures listed in this warning may result in equipment damage.

 **NOTE!**
This warning provides important information for the proper understanding and operation of the equipment.

1.2 SAFETY WARNINGS IN THE PRODUCT

The following symbols are attached to the product and require special attention:

 Indicates a high voltage warning.

 Electrostatic discharge sensitive components.
Do not touch them.

 Indicates that a ground (PE) must be connected securely.

 Indicates that the cable shield must be grounded.

 Indicates a hot surface warning.

1.3 PRELIMINARY RECOMMENDATIONS



DANGER!

Only trained personnel, with proper qualifications, and familiar with the CFW-11 and associated machinery shall plan and implement the installation, starting, operation, and maintenance of this equipment. The personnel shall follow all the safety instructions described in this manual and/or defined by the local regulations.

Failure to comply with the safety instructions may result in death, serious injury, and equipment damage.



DANGER!

Seulement personnes avec la qualification adéquate et familiarisation avec le CFW-11 et équipements associés doivent planifier ou implémenter l'installation, mise en marche, opération et entretien de cet équipement. Ces personnes doivent suivre toutes les instructions de sécurité indiquées dans ce manuel, et/ou définies par normes locales.

L'inobservance des instructions de sécurité peut résulter en risque de vie et/ou dommages de cet équipement.



NOTE!

For the purpose of this manual, qualified personnel are those trained and able to:

1. Install, ground, power-up, and operate the CFW-11 according to this manual and to the current legal safety procedures.
2. Use the protection equipment according to the established regulations.
3. Provide first aid.



DANGER!

Always disconnect the main power supply before touching any electrical device associated with the inverter. Several components may remain charged with high voltage and/or in movement (fans), even after the AC power supply has been disconnected or turned off.

Wait at least 10 minutes to guarantee the fully discharge of capacitors.

Always connect the equipment frame to the ground protection (PE).



DANGER!

Débranchez toujours l'alimentation principale avant d'entrer en contact avec un appareil électrique associé au variateur.

Plusieurs composants peuvent rester chargés à un potentiel électrique élevé et/ou être en mouvement (ventilateurs), même après la déconnexion ou la coupure de l'alimentation en courant alternatif.

Attendez au moins 10 minutes que les condensateurs se déchargent complètement.

Raccordez toujours la masse de l'appareil à une terre protectrice (PE).



ATTENTION!

The electronic boards contain components sensitive to electrostatic discharges. Do not touch the components and terminals directly. If needed, touch first the grounded metal frame or wear an adequate ground strap.

**Do not perform a withstand voltage test on any part of the inverter!
If needed, please, consult WEG.**

**NOTE!**

Frequency inverters may cause interference in other electronic devices. Follow the recommendations listed in [Chapter 3 INSTALLATION AND CONNECTION](#) on page 3-1, to minimize these effects.

**NOTE!**

Fully read this manual before installing or operating the inverter.

**DANGER!****Crushing Hazard**

In order to ensure safety in load lifting applications, electric and/or mechanical devices must be installed outside the inverter for protection against accidental fall of load.

**DANGER!**

This product was not designed to be used as a safety element. Additional measures must be taken so as to avoid material and personal damages.

The product was manufactured under strict quality control, however, if installed in systems where its failure causes risks of material or personal damages, additional external safety devices must ensure a safety condition in case of a product failure, preventing accidents.

**DANGER!****Risque d'écrasement**

Afin d'assurer la sécurité dans les applications de levage de charges, les équipements électriques et/ou mécaniques doivent être installés hors du variateur pour éviter une chute accidentelle des charges.

**DANGER!**

Ce produit n'est pas conçu pour être utilisé comme un élément de sécurité. Des précautions supplémentaires doivent être prises afin d'éviter des dommages matériels ou corporels. Ce produit a été fabriqué sous un contrôle de qualité conséquent, mais s'il est installé sur des systèmes où son dysfonctionnement entraîne des risques de dommages matériels ou corporels, alors des dispositifs de sécurité externes supplémentaires doivent assurer des conditions de sécurité en cas de défaillance du produit, afin d'éviter des accidents.

2 GENERAL INSTRUCTIONS

2.1 ABOUT THE MANUAL

This manual exposes how to install, to start-up in V/f (scalar) mode, the main characteristics and shows how to troubleshoot the most common problems of the CFW-11 inverter series frame size E models.

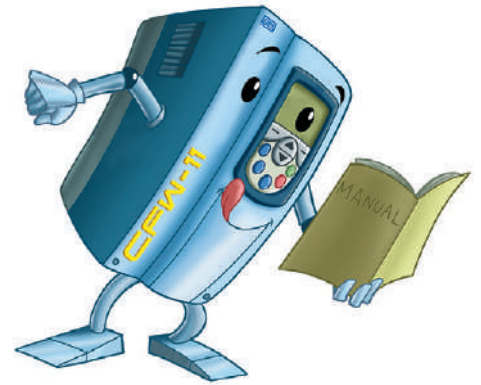

It is also possible to operate the CFW-11 in the following control modes: VVV, Sensorless Vector and Vector with Encoder. For further details on the inverter operation with other control modes, refer to the programming manual.



ATTENTION!

The operation of this equipment requires installation instructions and detailed operation provided in the user's manual, programming manual and manuals/guides for kits and accessories. The user's manual and the parameters quick reference are supplied in a hard copy together with the inverter. The user guides are also provided in a hard copy along with the kit/accessories. The other manuals are available at www.weg.net.

A printed copy of the files available on WEG's website can be requested at your local WEG dealer.

For information on other functions, accessories, and communication, please refer to the following manuals:

- Programming manual, with a detailed description of the parameters and advanced functions of the CFW-11.
- Incremental encoder interface module manual.
- I/O expansion module manual.
- RS-232/RS-485 serial communication manual.
- CANopen slave communication manual.
- Anybus-CC communication manual.
- DeviceNet communication manual.
- Ethercat communication manual.
- Profibus DP communication manual.
- Symbinet communication manual.
- SoftPLC manual.

2.2 TERMS AND DEFINITIONS

Normal Duty Cycle (ND): inverter duty cycle that defines the maximum continuous operation current ($I_{\text{nom-ND}}$) and the overload current (110 % for 1 minute). The ND cycle is selected by setting P0298 (Application) = 0 (Normal Duty (ND)). This duty cycle shall be used for the operation of motors that are not subjected to high torque loads (with respect to the motor rated torque) during its operation, starting, acceleration or deceleration.

$I_{\text{nom-ND}}$: inverter rated current for use with the normal duty (ND) cycle.
Overload: $1.1 \times I_{\text{nom-ND}} / 1$ minute.

Heavy Duty Cycle (HD): inverter duty cycle that defines the maximum continuous operation current ($I_{\text{nom-ND}}$) and the overload current (150 % for 1 minute). The HD cycle is selected by setting P0298 (Application) = 1 (Heavy Duty (HD)). This duty cycle shall be used for the operation of motors that are subjected to high torque (with respect to the motor rated torque) during its operation, starting, acceleration, or deceleration.

$I_{\text{nom-ND}}$: inverter rated current for use with the heavy duty (HD) cycle.
Overload: $1.5 \times I_{\text{nom-ND}} / 1$ minute.

Rectifier: the input circuit of the inverters that converts the input AC voltage into DC; it is made of thyristors and power diodes.

Pre-charge Circuit: charges the DC Link capacitors with limited current, which avoids higher peak currents at the inverter power-up.

DC Link: inverter intermediate circuit; DC voltage obtained from the rectification of the AC input voltage or from an external power supply. It feeds the inverter output IGBTs bridge.

U, V, W Arms: set of two IGBTs of the inverter output phases U, V, and W.

IGBT: insulated Gate Bipolar Transistor; basic component of the output inverter bridge. The IGBT works as an electronic switch in the saturated (closed switch) and cut-off (open switch) modes.

Braking IGBT: works as a switch to activate the braking resistors; it is controlled by the DC Link voltage level.

Gate Driver: circuit used to turn-on and turn-off the IGBTs.

PWM: pulse width modulation; pulsed voltage that feeds the motor.

Switching Frequency: frequency of the IGBTs switching in the inverter bridge, normally expressed in kHz.

Heatsink: it is a metal part designed for dissipating the heat generated by the power semiconductors.

PE: protective earth.

MOV: metal oxide varistor.

PTC: resistor which resistance value in ohms increases proportionally to the temperature increase; used as a temperature sensor in electrical motors.

NTC: resistor which resistance value in ohms decreases proportionally to the temperature increase; used as a temperature sensor in power modules.



HMI - Human Machine Interface: it is a device that allows the motor control, and the visualization and modification of the inverter parameters. The CFW-11 HMI presents keys for the motor command, navigation keys and a graphic LCD display.

FLASH Memory: non-volatile memory that can be electronically written and erased.

RAM Memory: random access memory (volatile).

USB: universal serial bus; is a serial bus standard that allows devices to be connected using the "Plug and Play" concept.

General Enable: when activated, this function accelerates the motor via acceleration ramp set in the inverter. When deactivated, this function immediately blocks the PWM pulses. The general enable function may be controlled through a digital input set to this function or via serial communication.

Start/Stop: when enabled in the inverter (start), this function accelerates the motor via acceleration ramp up to the speed reference. When disabled (stop), this function decelerates the motor via deceleration ramp up to the complete motor stop; at this point, the PWM pulses are blocked. The start/stop function may be controlled through a digital input set for this function or via serial communication. The operator keys  (Start) and  (Stop) of the keypad work in a similar way.

STO: safe torque off; functional safety function available as an option in CFW-11 inverter series. When STO function is enabled the inverter guarantees that there is no movement of the motor shaft. It's also called safety stop function in CFW-11 documentation.

PLC: programmable logic controller.

TBD: value to be defined.

AC: alternated current.

DC: direct current.

Amp, A: ampères.

°C: celsius degree.

CFM: cubic feet per minute; unit of flow.

cm: centimeter.

°F: fahrenheit degree.

Hz: hertz.

ft: foot.

hp: horse power = 746 Watts; unit of power, used to indicate the mechanical power of electrical motors.

in: Inch.

kg: kilogram = 1000 grams.

kHz: kilohertz = 1000 Hertz.

l/s: liters per second.

lb: pound.

m: meter.

mA: miliampère = 0.001 Ampère.

min: minute.

mm: millimeter.

ms: millisecond = 0.001 seconds.

Nm: newton meter; unit of torque.

rms: "root mean square"; effective value.

rpm: revolutions per minute; unit of speed.

s: second.

V: volts.

Ω: ohms.

2.3 ABOUT THE CFW-11

The CFW-11 frequency inverter is a high performance product designed for speed and torque control of three-phase induction motors. The main characteristic of this product is the "Vectrue" technology, which has the following advantages:

- Scalar control (V/f), VVW, or vector control programmable in the same product.
- The vector control may be programmed as "sensorless" (which means standard motors without using encoders) or as "vector control" with the use of an encoder.
- The "sensorless" control allows high torque and fast response, even in very low speeds or at the starting.
- The "vector with encoder" control allows high speed precision for the whole speed range (even with a standstill motor).
- "Optimal Braking" function for the vector control, allowing the controlled braking of the motor and avoiding the use of the braking resistor in some applications.
- "Self-Tuning" feature for vector control. It allows the automatic adjustment of the regulators and control parameters from the identification (also automatic) of the motor parameters and load.

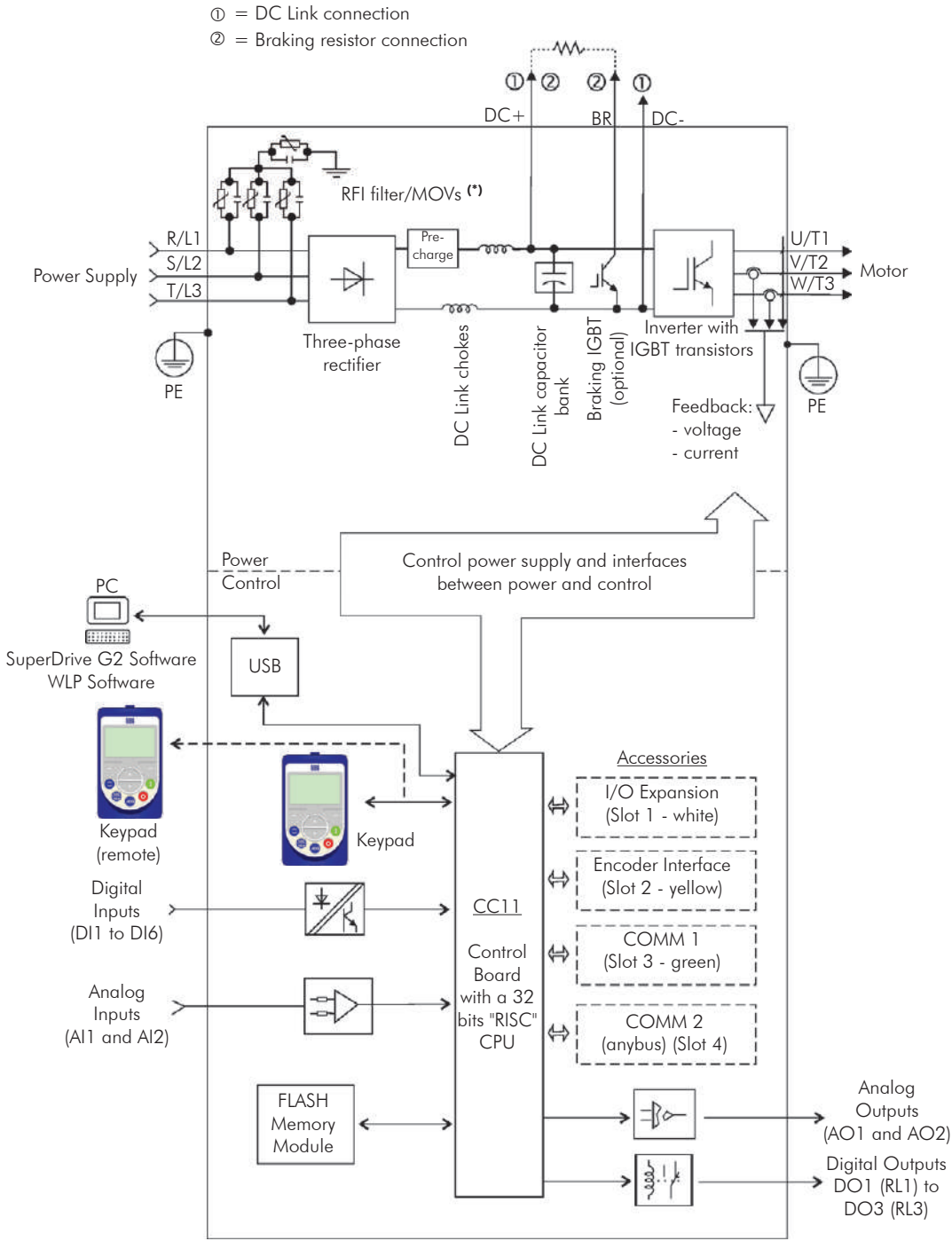

(*) The capacitor of RFI filter and MOV connected to the ground must be disconnected with IT network, high impedance grounding network and corner-grounded delta networks. Refer to [Item 3.2.3.2.1 IT Networks on page 3-17](#) for more details.

Figure 2.1 - Block diagram for the CFW-11

2

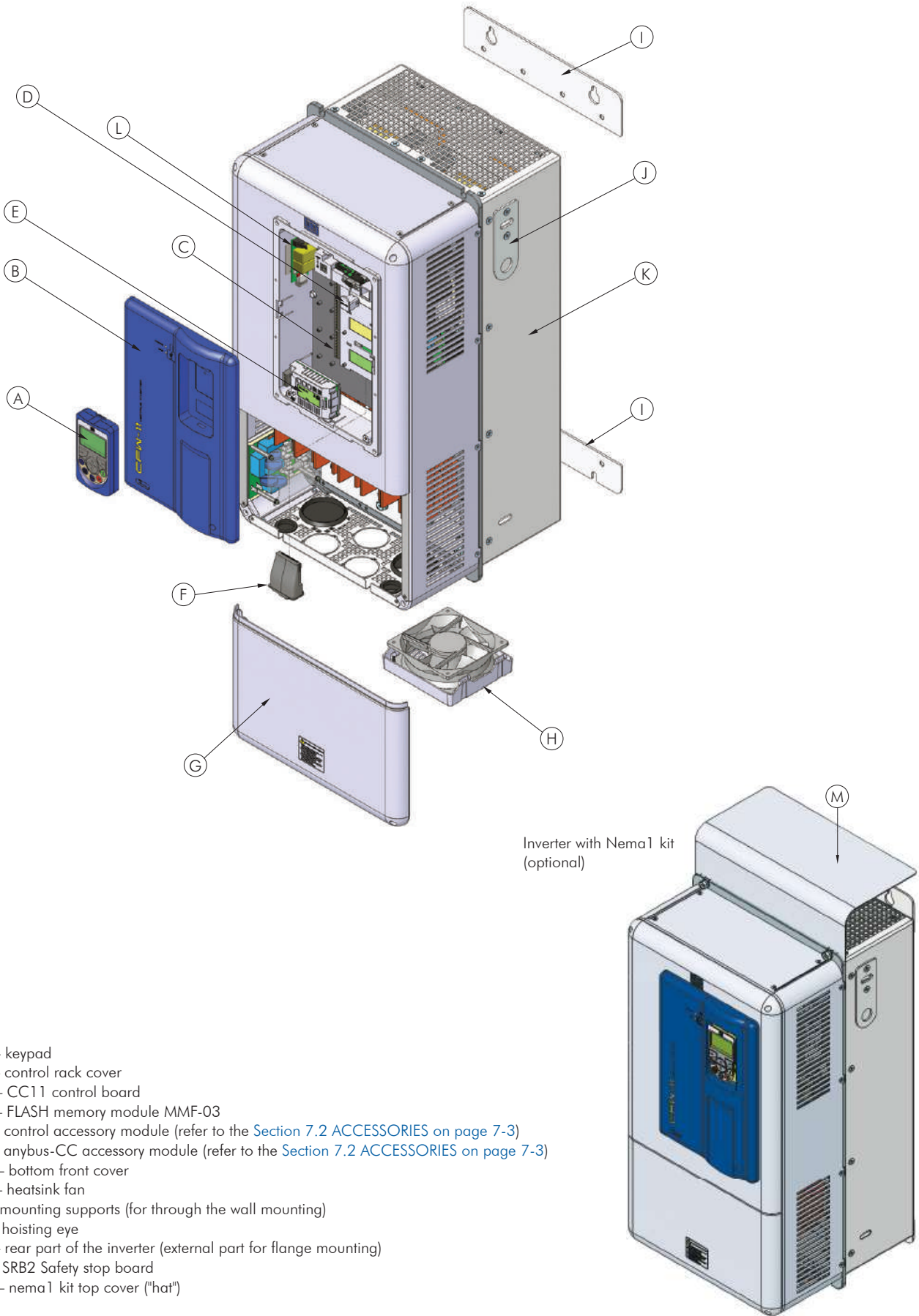

- A – keypad
- B – control rack cover
- C – CC11 control board
- D – FLASH memory module MMF-03
- E – control accessory module (refer to the [Section 7.2 ACCESSORIES](#) on page 7-3)
- F – anybus-CC accessory module (refer to the [Section 7.2 ACCESSORIES](#) on page 7-3)
- G – bottom front cover
- H – heatsink fan
- I – mounting supports (for through the wall mounting)
- J – hoisting eye
- K – rear part of the inverter (external part for flange mounting)
- L – SRB2 Safety stop board
- M – nema1 kit top cover ("hat")

Figure 2.2 - Main components of the CFW-11

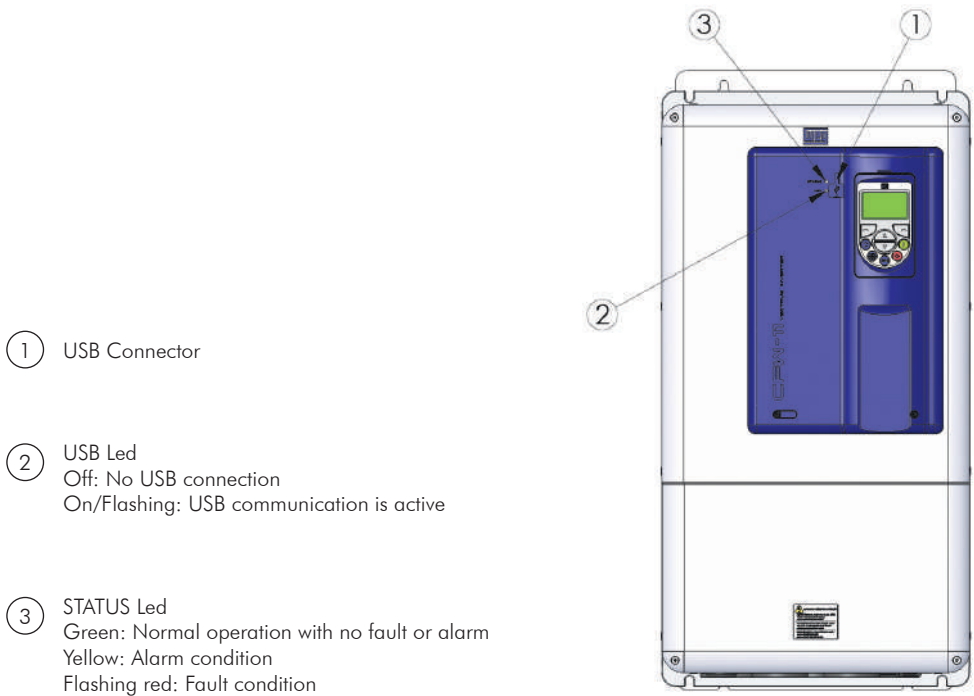

Figure 2.3 - LEDs and USB connector

2.4 IDENTIFICATION LABELS FOR THE CFW-11

There are two nameplates on the CFW-11: one complete nameplate is affixed to the side of the inverter and a simplified one is located under the keypad. The nameplate under the keypad allows the identification of the most important characteristics of the inverter even if they are mounted side-by-side.

CFW-11 model	→	MOD. BRCFW110211T2SZ	←																					
WEG part number	→	MAT.: 10858753	←																					
Inverter net weight	→	PESO/WEIGHT: 65kg (143lb)	←																					
Input rated data (voltage, number of phases, rated currents for operation with ND and HD overload cycles, and frequency)	→	<table border="1"> <tr> <th></th> <th>LINE LINEA REDE</th> <th>OUTPUT SALIDA SAIDA</th> </tr> <tr> <td>VAC</td> <td>220-230V / 3~</td> <td>0-REDE 3~</td> </tr> <tr> <td>A (ND)</td> <td>211A</td> <td>211A</td> </tr> <tr> <td>80s/3s</td> <td></td> <td>232A / 318A</td> </tr> <tr> <td>A (HD)</td> <td>180A</td> <td>180A</td> </tr> <tr> <td>60s/3s</td> <td></td> <td>270A / 360A</td> </tr> <tr> <td>Hz</td> <td>50/60Hz</td> <td>0-300Hz</td> </tr> </table>		LINE LINEA REDE	OUTPUT SALIDA SAIDA	VAC	220-230V / 3~	0-REDE 3~	A (ND)	211A	211A	80s/3s		232A / 318A	A (HD)	180A	180A	60s/3s		270A / 360A	Hz	50/60Hz	0-300Hz	←
	LINE LINEA REDE	OUTPUT SALIDA SAIDA																						
VAC	220-230V / 3~	0-REDE 3~																						
A (ND)	211A	211A																						
80s/3s		232A / 318A																						
A (HD)	180A	180A																						
60s/3s		270A / 360A																						
Hz	50/60Hz	0-300Hz																						
Current specifications for operation with normal overload cycle (ND)	→	211A	←																					
Current specifications for operation with heavy overload cycle (HD)	→	180A	←																					
		17 M	←																					

Maximum surrounding air temperature

Serial number

Manufacturing date (17 corresponds to week and M to year)

Output rated data (voltage, number of phases, rated currents for operation with ND and HD overload cycles, overload currents for 1 min and 3 s, and frequency range)

FABRICADO NO BRASIL
HECHO EN BRASIL
MADE IN BRAZIL

UL LISTED IND. CONT. EQ. 2899

CE EAC

894-171-828951

(a) Nameplate affixed to the side of the inverter

CFW-11 model	→	BRCFW110211T2SZ	
WEG part number	→	10858753	←
		17M	←
		SERIAL#: 111111111	←

Manufacturing date (17 corresponds to week and M to year)

Serial number

(b) Nameplate located under the keypad

Figure 2.4 - (a) and (b) - Nameplates

2

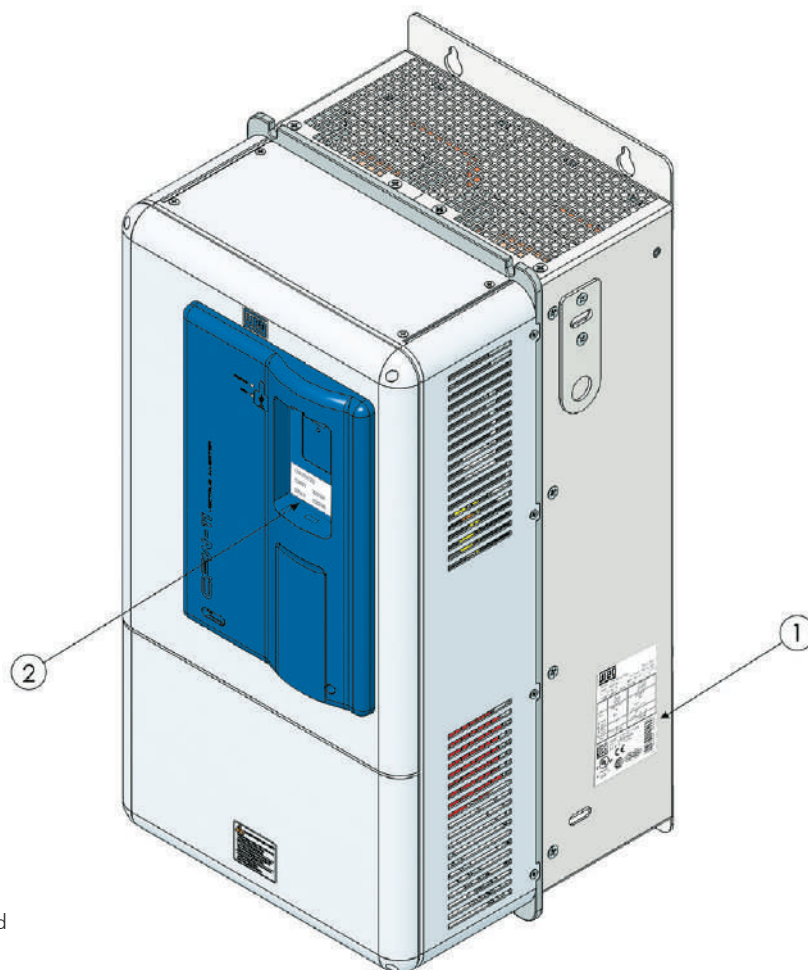

① Nameplate affixed to the side of the inverter

② Nameplate under the keypad

Figure 2.5 - Location of the nameplates

HOW TO CODIFY THE CFW-11 MODEL (SMART CODE)

		Inverter Model				Available Option Kits (can be installed in the product from the factory)									
Example	BR	CFW-11	0211	T	4	S	---	---	---	---	---	---	---	Z	
Field description	Market identification (defines the manual language and the factory settings)	WEG CFW-11 frequency inverter series	Rated output current for use with the Normal Duty (ND) cycle	Number of power phases	Power supply voltage	Option kit	Enclosure type	Keypad	Braking	RFI filter	Safety stop	24 Vdc external power supply for control	Special hardware	Special software	Character that identifies the code end
Available options	2 characters		220...230 V models: 0142 = 115 A (HD) / 142 A (ND) 0180 = 142 A (HD) / 180 A (ND) 0211 = 180 A (HD) / 211 A (ND) 380...480 V models: 0105 = 88 A (HD) / 105 A (ND) 0142 = 115 A (HD) / 142 A (ND) 0180 = 142 A (HD) / 180 A (ND) 0211 = 180 A (HD) / 211 A (ND)	T = three-phase power supply	2 = 220...230 V 4 = 380...480 V	S = standard product O = product with option kit	Blank = standard (IP20) N1 = Nema1 55 = IP55	Blank = standard keypad IC = no keypad (blind cover)	Blank = standard (no braking) GBT = with GBT DB = with braking	Blank = standard (with internal RFI filter)	Blank = standard (Safety Stop function is not available) Y = with Safety Stop function according to EN-954-1 category 3	Blank = standard (not available) W = 24 Vdc external power supply for control	Blank = standard H1 = special hardware #1 S1 = special software #1		

2.5 RECEIVING AND STORAGE

The CFW-11 frame size E models are supplied packed in wooden boxes.

There is an identification label affixed to the outside of this package, the same one that is affixed to the side of the inverter.

Follow the instructions below to remove the CFW-11 from the package:

- 1- Put the shipping container over a flat and stable area with the assistance of another two people.
- 2- Open the wood crate.
- 3- Remove all the packing material (the cardboard or styrofoam protection) before removing the inverter.

Check the following items once the inverter is delivered:

- Verify that the CFW-11 nameplate corresponds to the model number on your purchase order.
- Inspect the CFW-11 for external damage during transportation.

Report any damage immediately to the carrier that delivered your CFW-11 inverter.

If CFW-11 is to be stored for some time before use, be sure that it is stored in a clean and dry location that conforms to the storage temperature specification (between -25 °C and 60 °C (-13 °F and 140 °F)). Cover the inverter to prevent dust accumulation inside it.



ATTENTION!

Capacitor reforming is required if drives are stored for long periods of time without power. Refer to the procedures in [Section 6.5 PREVENTIVE MAINTENANCE on page 6-9](#).

3 INSTALLATION AND CONNECTION

This chapter provides information on installing and wiring the CFW-11. The instructions and guidelines listed in this manual shall be followed to guarantee personnel and equipment safety, as well as the proper operation of the inverter.



3.1 MECHANICAL INSTALLATION

3.1.1 Installation Environment

Avoid:

- Direct exposure to sunlight, rain, high humidity, or sea-air.
- Inflammable or corrosive gases or liquids.
- Excessive vibration.
- Dust, metallic particles, and oil mist.

Environment conditions for the operation of the inverter:

- Temperature: -10 °C to 45 °C (14 °F to 113 °F) - standard conditions (surrounding the inverter).

From 45 °C to 55 °C (113 °F to 131 °F) - current derating of 2 % each °C (or 1.11 % each °F) above 45 °C (113 °F).

- Inverters CFW-11 with IP55 degree protection: -10 °C to 40 °C (14 °F to 104 °F) - standard conditions (surrounding the inverter).

From 40 °C a 50 °C (104 °F to 122 °F) - current derating of 2 % for each degree Celsius above 40 °C (104 °F).

- Humidity: from 5 % to 95 % non-condensing.
- Altitude: up to 1000 m (3,300 ft) - standard conditions (no derating required).
- From 1000 m to 4000 m (3,300 ft to 13,200 ft) - apply current derating of 1% for each 100 m (328 ft) above 1000 m (3,300 ft) of altitude.
From 2000 m to 4000 m (6,600 ft to 13,200 ft) - apply maximum voltage derating (240 V for models 220...240 V, and 480 V for models 380...480 V) of 1.1 % for each 100 m (328 ft) above 2000 m (6,600 ft).
- Pollution degree: 2 (according to EN50178 and UL508C) with non-conductive pollution. Condensation shall not originate conduction through the accumulated residues.

3.1.2 Mounting Considerations

Consult the inverter weight at the [Table 8.1 on page 8-2](#).

Mount the inverter in the upright position on a flat and vertical surface.

External dimensions and fixing holes position according to the [Figure 3.1 on page 3-3](#). Refer to the [Section 8.5 MECHANICAL DATA on page 8-9](#) for more details.

First put the screws on the surface where the inverter will be installed, install the inverter and then tighten the screws.

Minimum mounting clearances requirements for proper cooling air circulation are specified in [Figure 3.2 on page 3-4](#).

Do not install heat sensitive components right above the inverter.



ATTENTION!

When arranging two or more inverters vertically, respect the minimum clearance A + B ([Figure 3.2 on page 3-4](#)) and provide an air deflecting plate so that the heat rising up from the bottom inverter does not affect the top inverter.



ATTENTION!

Provide conduit for physical separation of the signal, control, and power conductors (refer to [Section 3.2 ELECTRICAL INSTALLATION on page 3-10](#)).

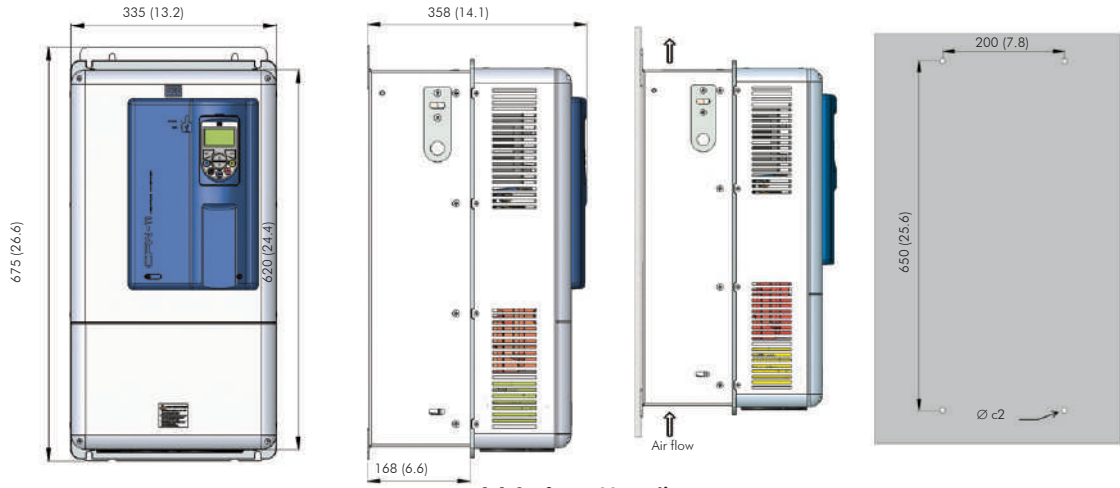

(a) Surface Mounting

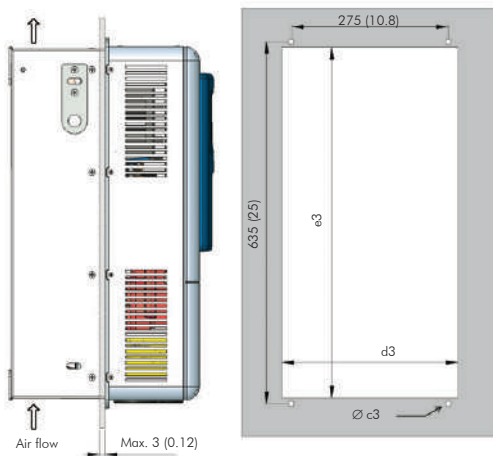

(b) Flange Mounting

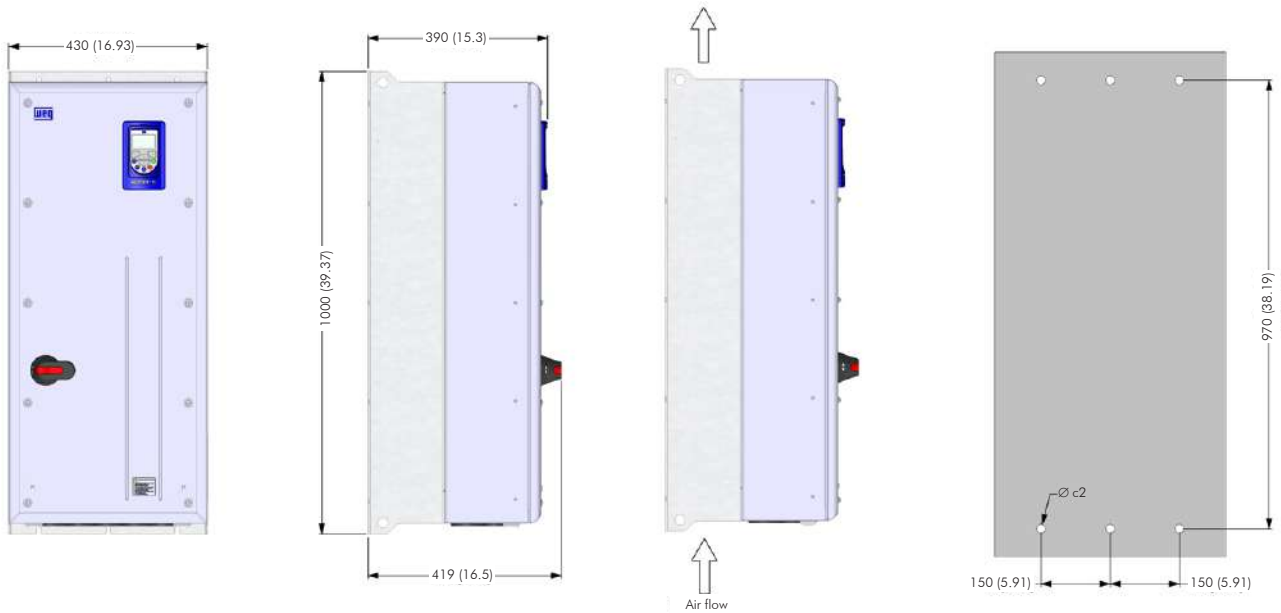

(c) Surface Mounting for Models with Optional Protection IP55

Model	c2	c3	d3	e3	Torque (*)
	M	M	mm (in)	mm (in)	N.m (lbf.in)
IP20/ Nema1	M8	M8	315 (12.40)	615 (24.21)	20.0 (177.0)
IP55	M8	-	-	-	20.0 (177.0)

Tolerances for dimensions d3 and e3: +1.0 mm (+0.039 in)

Tolerances for remaining dimensions: ± 1.0 mm (± 0.039 in)

(*) Recommended torque for the inverter mounting (valid for c2 and c3)

Figure 3.1 - (a) to (c) - Mechanical installation details - mm (in)

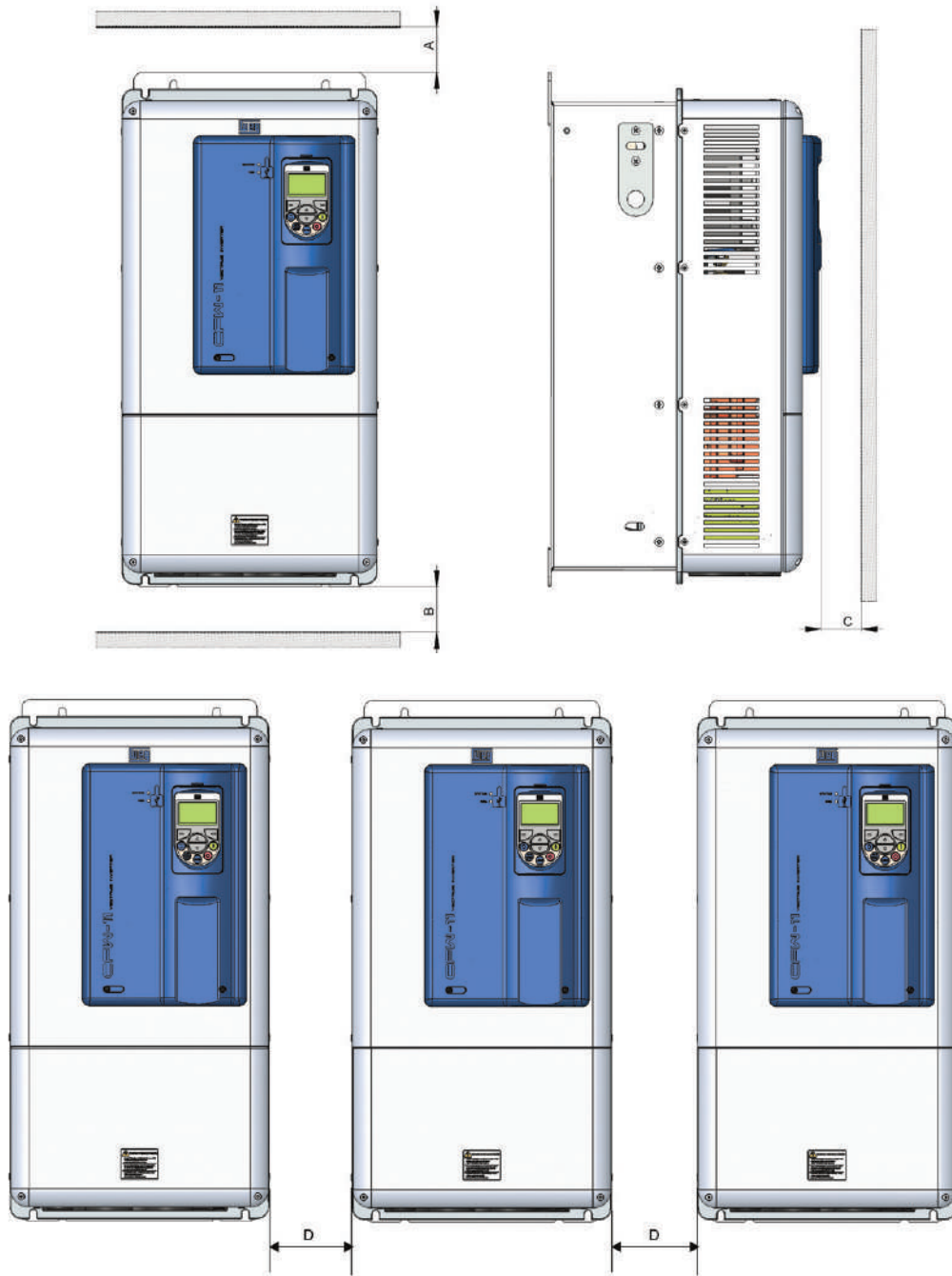

Model	A mm (in)	B mm (in)	C mm (in)	D mm (in)
CFW11 0142 T 2	100 (3.94)	130 (5.12)	20 (0.78)	40 (1.57)
CFW11 0180 T 2	150 (5.91)	250 (9.84)		80 (3.15)
CFW11 0211 T 2				
CFW11 0105 T 4	100 (3.94)	130 (5.12)		40 (1.57)
CFW11 0142 T 4	150 (5.91)	250 (9.84)		80 (3.15)
CFW11 0180 T 4				
CFW11 0211 T 4				

Tolerance: ±1.0 mm (±0.039 in)

Figure 3.2 - Free spaces for ventilation, above, below, at the front and at the sides of the inverter

3.1.3 Cabinet Mounting

There are two possibilities for mounting the inverter: through the wall mounting or flange mounting (the heatsink is mounted outside the cabinet and the cooling air of the power module is kept outside the enclosure). The following information shall be considered in these cases:

Surface assembly:

- ☑ Provide adequate exhaustion so that the internal cabinet temperature is kept within the allowable operating range of the inverter.
- ☑ The power dissipated by the inverter at its rated condition, as specified in [Table 8.1 on page 8-2](#) to [Table 8.5 on page 8-4](#) "Dissipated power in Watts - Through the wall mounting".
- ☑ The cooling air flow requirements, as shown in [Table 3.1 on page 3-5](#).
- ☑ The position and diameter of the mounting holes, according to [Figure 3.1 on page 3-3](#).

Flange assembly:

- ☑ The power specified in [Table 8.1 on page 8-2](#) to [Table 8.5 on page 8-4](#) "Dissipated power in Watts - Flange mounting" will be dissipated inside the cabinet. The other losses (power modules) will be dissipated at the external ventilation duct.
- ☑ The inverter securing supports (position I of [Figure 2.2 on page 2-6](#)) and the hoisting eyes (position J of [Figure 2.2 on page 2-6](#)) must be removed and repositioned according to the [Figure 3.3 on page 3-6](#) and [Figure 3.4 on page 3-6](#).
- ☑ The portion of the inverter that is located outside the cabinet has protection degree IP54. Provide an adequate gasket for the cabinet opening to ensure that the enclosure rating is maintained. Example: silicone gasket.
- ☑ Mounting surface opening dimensions and position/diameter of the mounting holes, as shown in [Figure 3.1 on page 3-3](#).

Table 3.1 - Cooling air flow for frame size E models

Model	CFM	l/s	m ³ /min
CFW11 0142 T 2	180	95	5.1
CFW11 0180 T 2	265	125	7.5
CFW11 0211 T 2	367(*)	174(*)	10.4(*)
CFW11 0105 T 4	138	65	3.9
CFW11 0142 T 4	180	95	5.1
CFW11 0180 T 4	265	125	7.5
CFW11 0211 T 4	367(*)	174(*)	10.4(*)

(*) With optional degree of protection IP55.

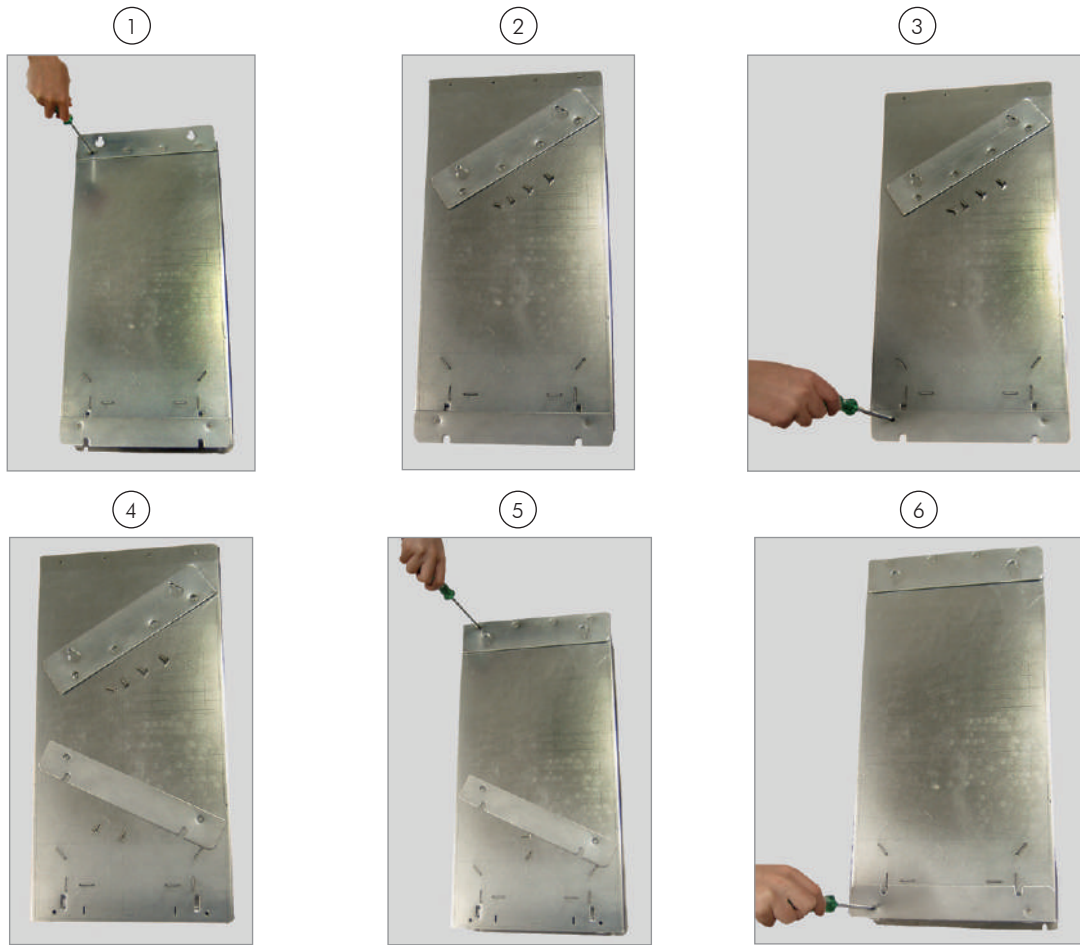

Figure 3.3 - Repositioning the mounting supports

3.1.4 Installation of the Inverter Hoisting Eyes

Two hoisting eyes for the inverter lifting, which are mounted at the inverter sides (rear part), are supplied. By inverting their position, as shown in the [Figure 3.4 on page 3-6](#), two points for hoisting the inverter, which are very useful during the mechanical installation of the inverter, are obtained.

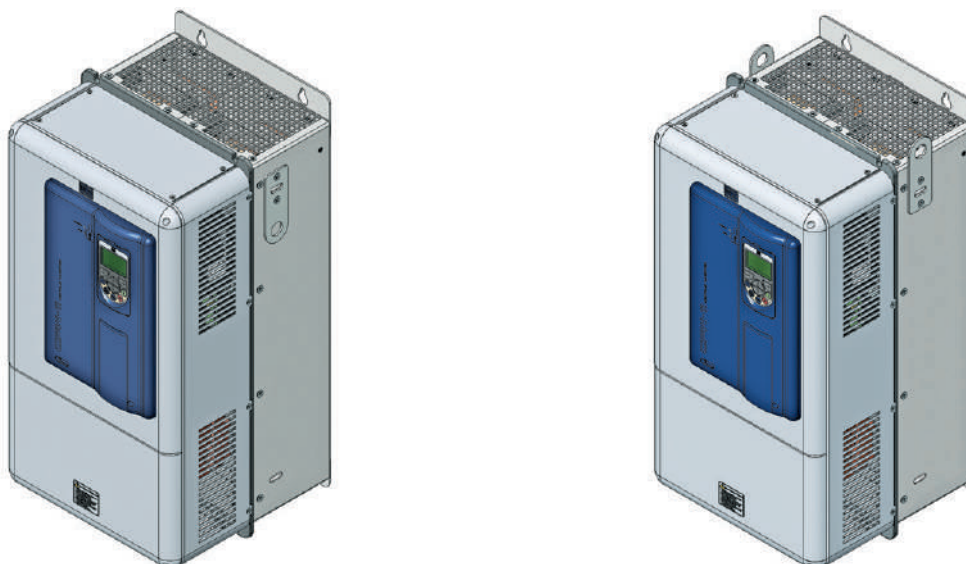

Figure 3.4 - Installation of the inverter hoisting eyes

3.1.5 Installation of the Inverter with Nema1 Kit (Option, CFW11....T...ON1...) on a Wall

- ☑ Fixing holes position and diameter according to the [Figure 3.1 on page 3-3](#).
- ☑ External dimensions of the inverter with Nema1 kit according to the [Section 8.6 NEMA1 KIT on page 8-11](#).
- ☑ Fasten the inverter.
- ☑ Install the Nema1 kit top on the inverter as showed in the [Figure 3.5 on page 3-7](#) using the 2 M8 screws supplied with the product.

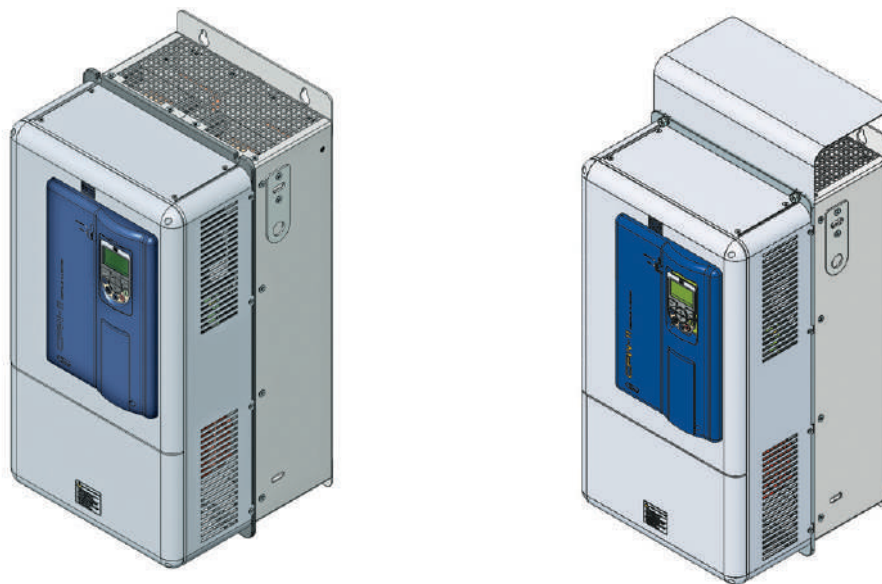

Figure 3.5 - Installation of the Nema1 kit top ("hat")

3.1.6 Access to the Control and Power Terminal Strips

It is necessary to remove the keypad (HMI) and the control rack cover in order to get access to the control terminal strip (see [Figure 3.6 on page 3-7](#)). In order to get access to the power terminal strip, remove the bottom front cover (see [Figure 3.7 on page 3-8](#)).



Figure 3.6 - HMI and control rack cover removal



Figure 3.7 - Bottom front cover removal

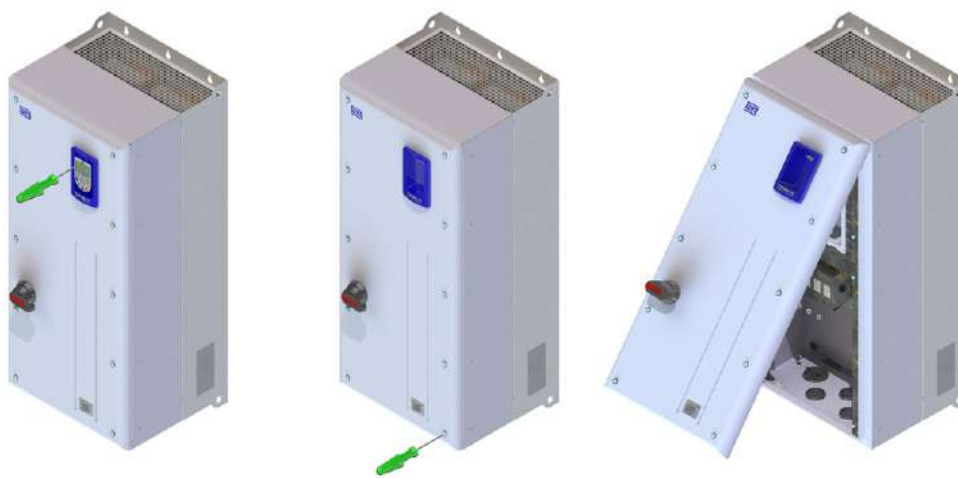

Figure 3.8 - Bottom front cover removal for models with optional IP55

At the CFW11 0180 T 2 O N1, CFW11 0211 T 2 O N1, CFW11 0180 T 4 O N1 and CFW11 0211 T 4 O N1 inverters (supplied with Nema1 kit), it is also necessary to remove the front cover of the Nema1 kit bottom part in order to be able to execute the electrical installation of power - see the [Figure 3.9 on page 3-9](#).

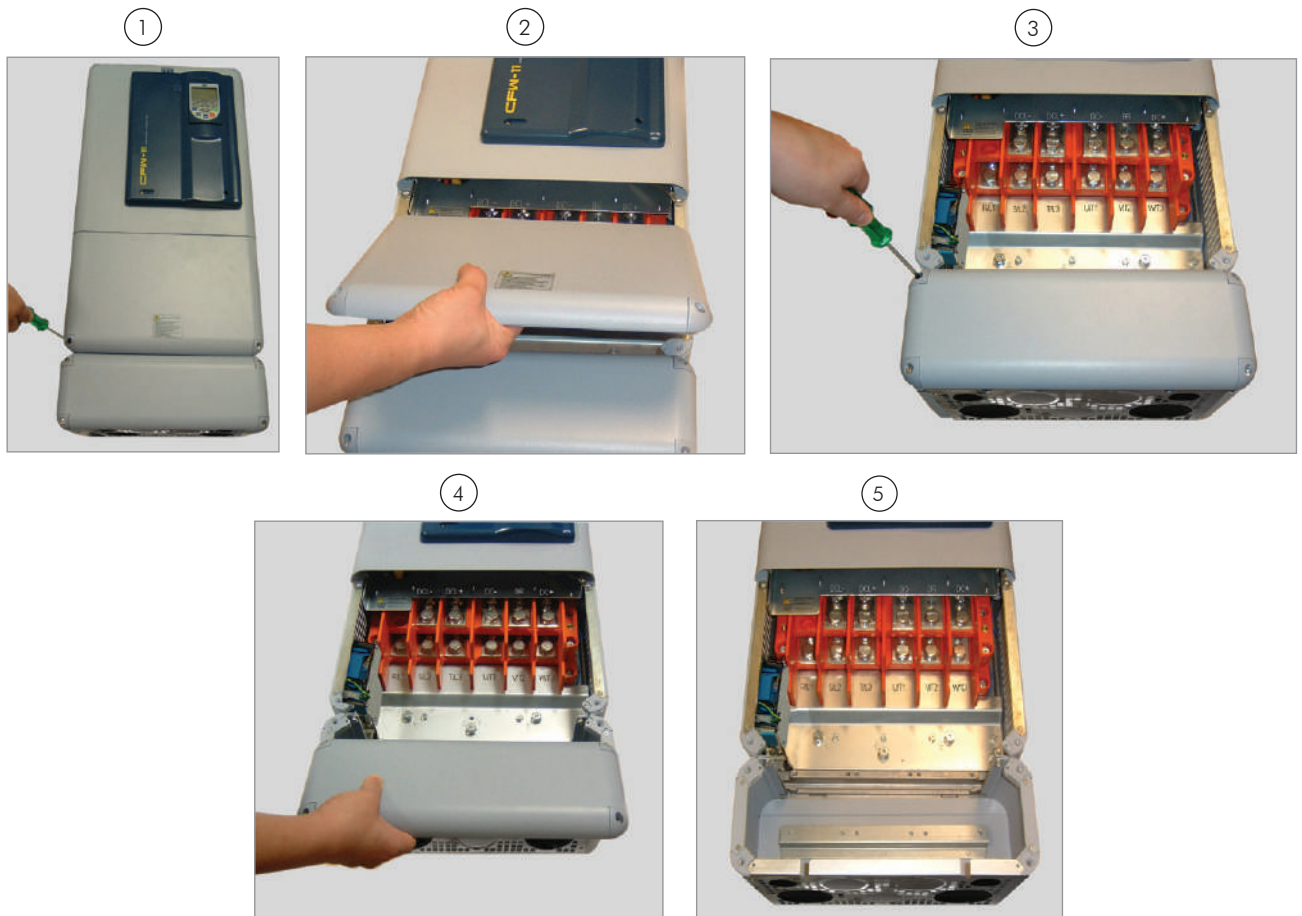

Figure 3.9 - Removal of the Nema1 kit bottom front cover at the CFW11 0180 T 2 O N1, CFW11 0211 T 2 O N1, CFW11 0180 T 4 O N1 and CFW11 0211 T 4 O N1 inverters in order to get access to the power terminal block

3.1.7 Removal of the Cable Passage Plate

When it is not necessary neither IP20 nor Nema1 protection degree, the cable passage plate may be removed in order to make the inverter electric installation easier. Remove the 4 M4 screws, according to the procedure presented in the [Figure 3.10](#) on page 3-9.

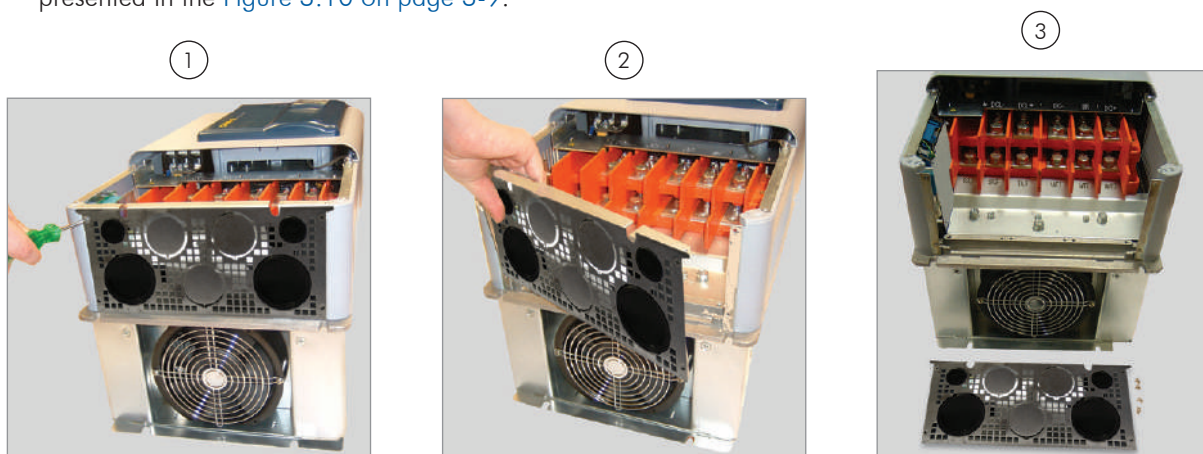

Figure 3.10 - Removal of the cable passage plate

3.1.8 HMI Installation at the Cabinet Door or Command Panel (Remote HMI)

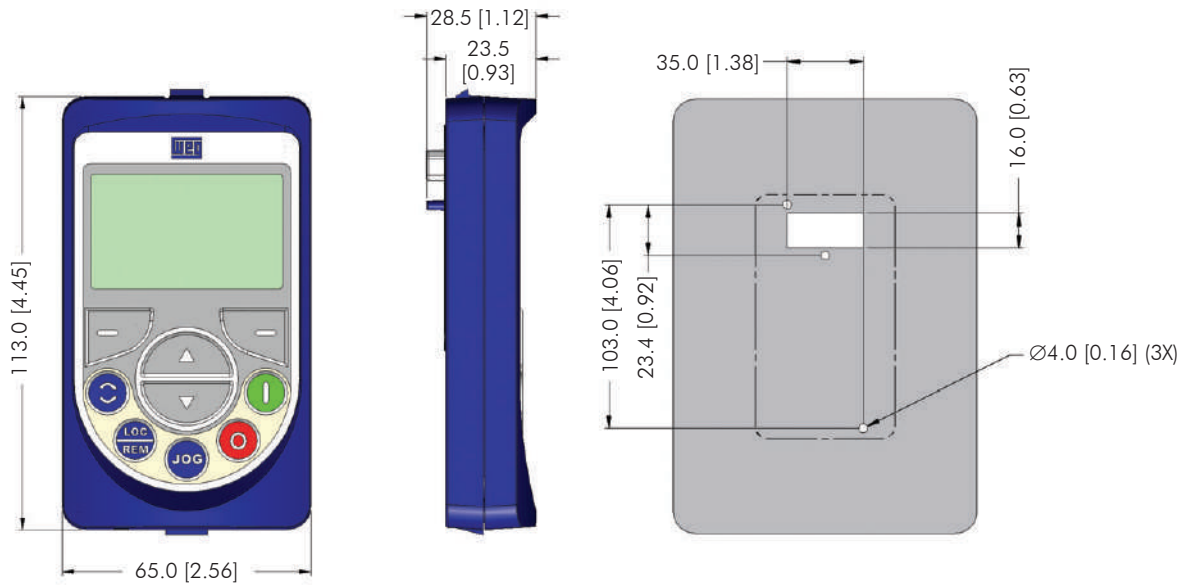

Figure 3.11 - Data for the HMI installation at the cabinet door or command panel – mm [in]

The keypad frame accessory can also be used to fix the HMI, as mentioned in the Table 7.1 on page 7-4 of models of the accessories.

3.2 ELECTRICAL INSTALLATION



DANGER

The following information is merely a guide for proper installation. Comply with applicable local regulations for electrical installations.



DANGER

Les informations suivantes constituent uniquement un guide pour une installation correcte. Respectez les réglementations locales en vigueur pour les installations électriques.



DANGER

Make sure the AC power supply is disconnected before starting the installation.



DANGER

Vérifiez que l'alimentation secteur CA est débranchée avant de commencer l'installation.



ATTENTION!

Integral solid state short circuit protection does not provide branch circuit protection. Branch circuit protection must be provided in accordance with applicable local codes.

3.2.1 Identification of the Power and Grounding Terminals

R/L1, S/L2, T/L3: AC power supply.

U/T1, V/T2, W/T3: motor connection.

DC+: this is the positive potential terminal in the DC Link circuit.

BR: braking resistor connection.

DC-: this is the negative potential terminal in the DC Link circuit.

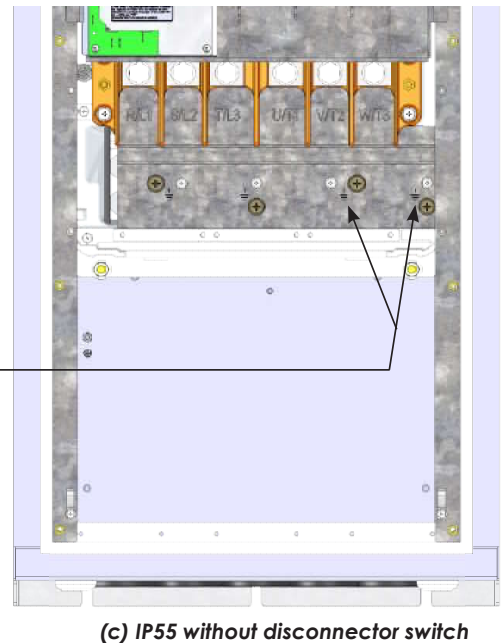
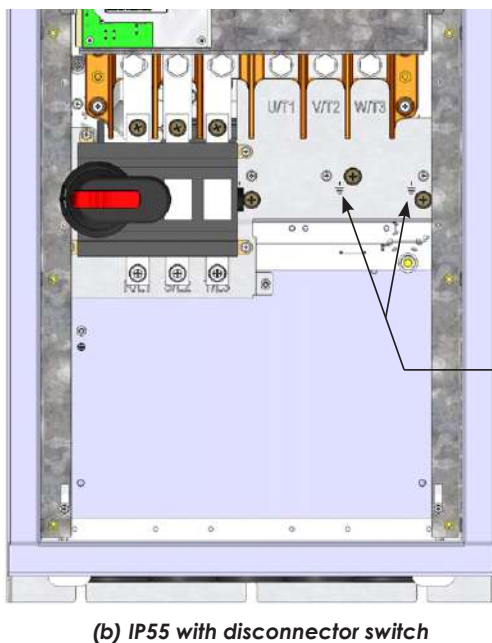
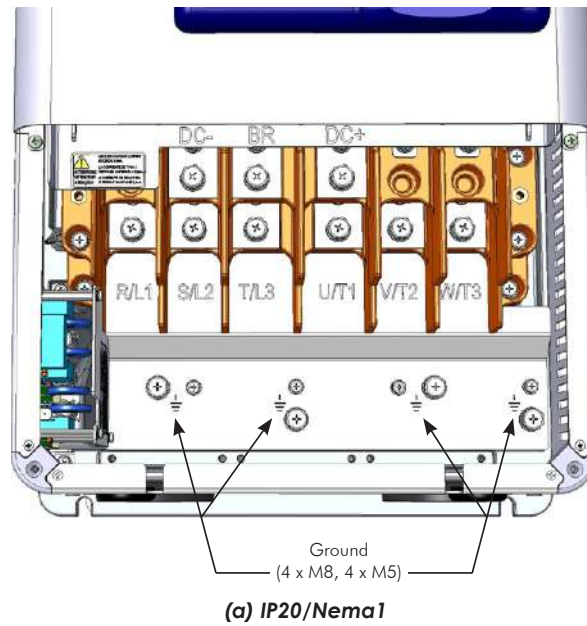

Figure 3.12 - Grounding and power terminals

3.2.2 Power/Grounding Wiring and Fuses



ATTENTION!

Use proper cable lugs for the power and grounding connection cables.



ATTENTION!

Sensitive equipment such as PLCs, temperature controllers, and thermal couples shall be kept at a minimum distance of 0.25 m (9.84 in) from the frequency inverter and from the cables that connect the inverter to the motor.



DANGER!

Wrong cable connection:

- The inverter will be damaged in case the input power supply is connected to the output terminals (U/T1, V/T2, or W/T3).
- Check all the connections before powering up the inverter.
- In case of replacing an existing inverter by a CFW-11, check if the installation and wiring is according to the instructions listed in this manual.



DANGER!

Mauvaise connexion des câbles:

- Le variateur sera endommagé si l'alimentation d'entrée est connectée aux bornes de sortie (U/T1, V/T2 ou W/T3).
- Vérifier toutes les connexions avant de mettre le variateur sous tension
- En cas de remplacement d'un variateur existant par un CFW-11, vérifier si l'installation et le câblage sont conformes aux instructions figurant dans ce manuel.



ATTENTION!

Residual Current Device (RCD):

- When installing an RCD to guard against electrical shock, only devices with a trip current of 300 mA should be used on the supply side of the inverter.
- Depending on the installation (motor cable length, cable type, multimotor configuration, etc.), RCD nuisance trips may occur. Contact the RCD manufacturer for selecting the most appropriate device to be used with inverters.









NOTE!

The wire gauge values listed in [Table 3.2 on page 3-13](#) are orientative values. Installation conditions and the maximum permitted voltage drop shall be considered for the proper wiring sizing.

Input fuses:

- ☑ Use High Speed Fuses at the input for the protection of the inverter rectifier and wiring refer to [Table 3.2 on page 3-13](#) for selecting the appropriate fuse rating (consider the cold current extinction value (not the melting value)) to protect the input rectifier diodes of the inverter and wiring.
- ☑ In order to meet UL requirements, use class **J** fuses at the inverter supply with a current not higher than the values of [Table 3.4 on page 3-17](#).
- ☑ Optionally, slow blow fuses can be used at the input they must be sized for 1.2 x the inverter rated input current. In this case, the installation is protected against short-circuit, but not the inverter input rectifier. This may result in major damage to the inverter in the event of an internal component failure.

Table 3.2 - Recommended wire size/fuses - use only copper wire [75 °C (167 °F)]

Model	Frame Size	Power Terminal			Over-load Class	Wire Size			Fuse [A]	Fuse I ² t [A ² s]
		Terminals	Bolt (Wrench/Screw Head Type)	Recommended Torque N.m (lbf.in)		mm ²	AWG	Terminals		
CFW11 0142 T 2	E	R/L1,S/L2,T/L3, U/T1,V/T2,W/T3, DC+,DC-, DCL+,DCL-	M8 (Phillips hex head)	15 (132.75)	HD	50	1/0	Ring tongue terminal	250	39200
					ND	70	2/0			
CFW11 0180 T 2	E		M5 and M8 (Phillips hex head)	M5: 3.5 (31.0); M8: 10 (88.5)	HD/ND	35	2	Ring tongue terminal	350	218000
		R/L1,S/L2,T/L3, U/T1,V/T2,W/T3, DC+,DC-, DCL+,DCL-	M10 (hexagonal screw) ⁽¹⁾	30 (265.5)	HD	70 (or 2 x 25)	2/0 (or 2 x 4)			
CFW11 0211 T 2	E		M5 and M8 (Phillips hex head)	M5: 3.5 (31.0); M8: 10 (88.5)	HD/ND	50	1	Ring tongue terminal	400	218000
		R/L1,S/L2,T/L3, U/T1,V/T2,W/T3, DC+,DC-, DCL+,DCL-	M10 (hexagonal screw) ⁽¹⁾	30 (265.5)	HD	120 (or 2 x 35)	4/0 (or 2 x 2)			
CFW11 0105 T 4	E		M5 and M8 (Phillips hex head)	M5: 3.5 (31.0); M8: 10 (88.5)	HD/ND	70	2/0	Ring tongue terminal	160	39200
		R/L1,S/L2,T/L3, U/T1,V/T2,W/T3, DC+,DC-, DCL+,DCL-	M8 (Phillips hex head)	15 (132.75)	HD	35	2			
CFW11 0142 T 4	E		M5 and M8 (Phillips hex head)	M5: 3.5 (31.0); M8: 10 (88.5)	HD/ND	35	2	Ring tongue terminal	250	39200
		R/L1,S/L2,T/L3, U/T1,V/T2,W/T3, DC+,DC-, DCL+,DCL-	M8 (Phillips hex head)	15 (132.75)	HD	50	1/0			
CFW11 0180 T 4	E		M5 and M8 (Phillips hex head)	M5: 3.5 (31.0); M8: 10 (88.5)	HD/ND	50	1	Ring tongue terminal	350	218000
		R/L1,S/L2,T/L3, U/T1,V/T2,W/T3, DC+,DC-, DCL+,DCL-	M10 (hexagonal screw) ⁽¹⁾	30 (265.5)	HD	70 (or 2 x 25)	2/0 (or 2 x 4)			
CFW11 0211 T 4	E		M5 and M8 (Phillips hex head)	M5: 3.5 (31.0); M8: 10 (88.5)	HD/ND	70	2/0	Ring tongue terminal	400	218000
		R/L1,S/L2,T/L3, U/T1,V/T2,W/T3, DC+,DC-, DCL+,DCL-	M10 (hexagonal screw) ⁽¹⁾	30 (265.5)	HD	120 (or 2 x 35)	4/0 (or 2 x 2)			

(1) IP55 models: R/L1,S/L2,T/L3 using hexagonal screw M8 (Phillips hex head).

Table 3.3 - (a) and (b) - Recommended terminals for power connections
(a) Cables with size in mm²

Wire Size [mm ²]	Screw	Manufacturer	Lug Terminal, Code	Crimping Tool Code	Number of Crimps
25	M5	Hollingsworth	RM 25 -5	H 6.500	1
		Tyco	33468	59975-1	1
	M8	Hollingsworth	RM 25-8	H 6.500	1
		Burndy (FCI)	YA3CL	Tool without die: MY29-3 or Y644 or Y81 Tool+die: Y46 or Y35 or Y750 / U3CRT	1
		Tyco	33470	59975-1	1
	M10	Hollingsworth	RM 25-10	H 6.500	1
Tyco		33471	59975-1	1	
35	M5	Hollingsworth	RM 35-5	H 6.500	1
		Burndy (FCI)	YA2CL2	Tool without die: MY29-3 or Y644 or Y81 Tool+die: Y46 or Y35 or Y750 / U2CRT	1
		Tyco	330301	59975-1	1
	M8	Hollingsworth	RM 35-8	H 6.500	1
		Burndy (FCI)	YAC2CL	Tool without die: MY29-3 or Y644 or Y81 Tool Tool+die: Y46 or Y35 or Y750 / U2CRT	1
		Tyco	322870	59975-1	1
50	M5	Hollingsworth	RM 50-5	H 6.500	1
		Burndy (FCI)	YA1CL2	Tool without die: MY29-3 or Y644 or Y81 Tool+die: Y46 or Y35 or Y750 / U1CRT	1
		Tyco	36915	Manual tool: 1490748-1, Jaw: 1490413-5 + 1490414-3	1
	M8	Hollingsworth	RM 50-8	H 6.500	1
		Burndy (FCI)	YA1CL	Tool without die: MY29-3 or Y644 or Y81 Tool+die: Y46 or Y35 or Y750 / U1CRT	1
		Tyco	36916	Manual tool: 1490748-1, Jaw: 1490413-5 + 1490414-3	1
	M10	Hollingsworth	RM 50-10	H 6.500	1
		Burndy (FCI)	YA1CL4	Tool without die: MY29-3 or Y644 or Y81 Tool+die: Y46 or Y35 or Y750 / U1CRT	1
		Tyco	36917	Manual tool: 1490748-1, Jaw: 1490413-5 + 1490414-3	1
70	M5	Hollingsworth	RM 70-5	H 6.500	1
		Burndy (FCI)	YA26L2	Tool without die: MY29-3 or Y644 or Y81 Tool+die: Y46 or Y35 or Y750 / U26RT	1
		Tyco	321869	Manual tool: 1490748-1, Jaw: 1490413-6 + 1490414-3	1
	M8	Hollingsworth	RM 70-8	H 6.500	1
		Burndy (FCI)	YA26L	Tool without die: MY29-3 or Y644 or Y81 Tool+die: Y46 or Y35 or Y750 / U26RT	1
		Tyco	321870	Manual tool: 1490748-1, Jaw: 1490413-6 + 1490414-3	1
	M10	Hollingsworth	RM 70-10	H 6.500	1
		Burndy (FCI)	YA26L4	Tool without die: MY29-3 or Y644 or Y81 Tool+die: Y46 or Y35 or Y750 / U26RT	1
		Tyco	321871	Manual tool: 1490748-1, Jaw: 1490413-6 + 1490414-3	1
120	M10	Hollingsworth	RM120-10	H 6.500	1
		Burndy (FCI)	YA29L4	Tool without die: MY29-3 or Y644 or Y81 Tool+die: Y46 or Y35 or Y750 / U29RT	1
		Tyco	322252	Hydraulic pump: 1804700-1 (electric) or 1583659-1 (foot pump), 1583662-1 -2 or -3 (1.8 m, 3 m or 6 m)	1
150	M10	Hollingsworth	RM150-10	H 6.500	1
		Burndy (FCI)	YA30L24	Tool without die: MY29-3 or Y644 or Y81 Tool+die: Y46 or Y35 or Y750 / U30RT	1
		Tyco	322252	Hydraulic pump: 1804700-1 (electric) or 1583659-1 (foot pump), 1583662-1 -2 or -3 (1.8 m, 3 m or 6 m)	1

(b) Cables with size in AWG

Wire size [AWG/kcmil]	Screw	Manufacturer	Lug Terminal, Code	Crimping Tool Code	Number of Crimps
4	M5	Hollingsworth	R 410	H 6.500	1
		Burndy (FCI)	YA4CL2	Tool without die: MY29-3 or Y644 or Y81 Tool+die: Y46 or Y35 or Y750 / U4CRT	1
		Tyco	33468	59975-1	1
	M8	Hollingsworth	R 4516	H 6.500	1
		Burndy (FCI)	YA4CL3	Tool without die: MY29-3 or Y644 or Y81 Tool+die: Y46 or Y35 or Y750 / U4CRT	1
		Tyco	33470	59975-1	1
	M10	Hollingsworth	R 438	H 6.500	1
		Burndy (FCI)	YA4CL4	Tool without die: MY29-3 or Y644 or Y81 Tool+die: Y46 or Y35 or Y750 / U4CRT	1
		Tyco	33471	59975-1	1
2	M5	Hollingsworth	R 210	H 6.500	1
		Burndy (FCI)	YA2CL2	Tool without die: MY29-3 or Y644 or Y81 Tool+die: Y46 or Y35 or Y750 / U2CRT	1
		Tyco	330301	59975-1	1
	M8	Hollingsworth	R 2516	H 6.500	1
		Burndy (FCI)	YA2CL	Tool without die: MY29-3 or Y644 or Y81 Tool+die: Y46 or Y35 or Y750 / U2CRT	1
		Tyco	322870	59975-1	1
1	M5	Hollingsworth	R 110	H 6.500	1
		Burndy (FCI)	YA1CL2	Tool without die: MY29-3 or Y644 or Y81 Tool+die: Y46 or Y35 or Y750 / U1CRT	1
		Tyco	330301	59975-1	1
	M8	Hollingsworth	R 1516	H 6.500	1
		Burndy (FCI)	YA1CL	Tool without die: MY29-3 or Y644 or Y81 Tool+die: Y46 or Y35 or Y750 / U1CRT	1
		Tyco	322870	59975-1	1
	M10	Hollingsworth	R 138	H 6.500	1
		Burndy (FCI)	YA1CL4	Tool without die: MY29-3 or Y644 or Y81 Tool+die: Y46 or Y35 or Y750 / U1CRT	1
Tyco		321600	59975-1	1	
1/0	M8	Hollingsworth	R 10516	H 6.500	1
		Burndy (FCI)	YA25L	Tool without die: MY29-3 or Y644 or Y81 Tool+die: Y46 or Y35 or Y750 / U25RT	1
		Tyco	36916	Manual tool: 1490748-1, Jaw: 1490413-5 + 1490414-3	1
2/0	M5	Hollingsworth	R 2010	H 6.500	1
		Burndy (FCI)	YA26L2	Tool without die: MY29-3 or Y644 or Y81 Tool+die: Y46 or Y35 or Y750 / U26RT	1
		Tyco	321869	Manual tool: 1490748-1 Jaw: 1490413-6 + 1490414-3	1
	M8	Hollingsworth	R 20516	H 6.500	1
		Burndy (FCI)	YA26L	Tool without die: MY29-3 or Y644 or Y81 Tool+die: Y46 or Y35 or Y750 / U26RT	1
		Tyco	321870	Manual tool: 1490748-1 Jaw: 1490413-6 + 1490414-3	1
	M10	Hollingsworth	R 2038	H 6.500	1
		Burndy (FCI)	YA26L4	Tool without die: MY29-3 or Y644 or Y81 Tool+die: Y46 or Y35 or Y750 / U26RT	1
		Tyco	321871	Manual tool: 1490748-1 Jaw: 1490413-6 + 1490414-3	1
4/0	M10	Hollingsworth	R 4038	H 6.500	1
		Burndy (FCI)	YA28L4	Tool without die: MY29-3 or Y644 or Y81 Tool+die: Y46 or Y35 or Y750 / U28RT	1
		Tyco	36932	Manual tool: 1490748-1 Jaw: 1490413-8 + 1490414-3	1
300	M10	Hollingsworth	R30038	H 6.500	1
		Burndy (FCI)	YA30L24	Tool without die: MY29-3 or Y644 or Y81 Tool+die: Y46 or Y35 or Y750 / U30RT	1
		Tyco	322252	Hydraulic pump: 1804700-1 (electric) or 1583659-1 (foot pump), 1583662-1 -2 or -3 (1.8 m, 3 m or 6 m)	1

3.2.3 Power Connections

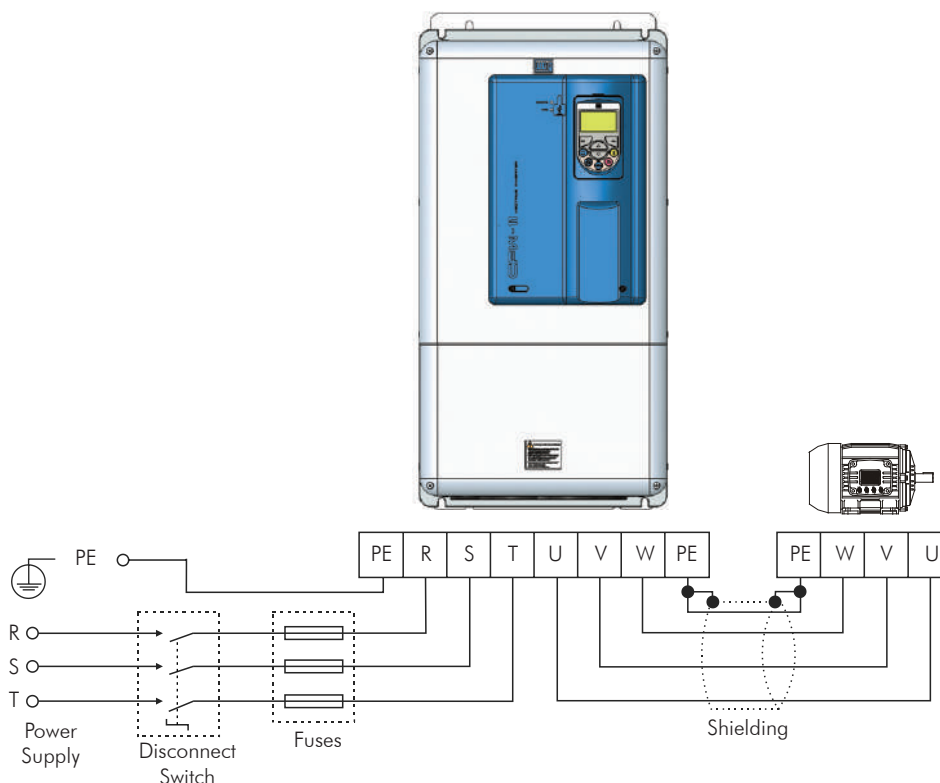

Figure 3.13 - Power and grounding connections

3.2.3.1 Input Connections



DANGER!

Provide a disconnect device for the input power supply of the inverter. This device shall disconnect the input power supply for the inverter when needed (for instance, during servicing).



DANGER!

Montez un dispositif de coupure sur l'alimentation du variateur. Ce composant déconnecte l'alimentation du variateur si cela est nécessaire (ex. pendant l'entretien et la maintenance).



ATTENTION!

A contactor or another device that frequently disconnects and reapplies the AC supply to the inverter in order to start and stop the motor may cause damage to the inverter power section. The drive is designed to use control signals for starting and stopping the motor. If used for that purpose, the input device must not exceed one operation per minute otherwise the inverter may be damaged.



ATTENTION!

The power supply that feeds the inverter shall have a grounded neutral. In case of IT networks, follow the instructions described in [Item 3.2.3.2.1 IT Networks on page 3-17](#).



NOTE!

The input power supply voltage must be compatible with the inverter rated voltage.



NOTE!

Power factor correction capacitors are not needed at the inverter input (R, S, T) and must not be installed at the output of the inverter (U, V, W).

3.2.3.2 AC Power Supply Considerations

- ☑ Suitable for circuits with capacity to deliver no more than:
 - 100 kA symmetric at 240 V or 480 V when the inverter is protected by fuses.
 - 65 kA symmetric at 240 V or 480 V when the inverter is protected by reverse-type circuit breakers (for compliance with UL standard and suggestion of circuit breaker current, see [Table 3.4 on page 3-17](#)).

Table 3.4 - Maximum rated current of the circuit breakers according to the inverter model

Model	Inverter Protection with Class J Fuses		Inverter Protection with Circuit Breaker		
	Rated Current of Fuse	Maximum Power Supply Short-Circuit Current	Rated Current of Circuit Breaker	Minimum Cabinet Dimensions (depth x height x width)	Maximum Power Supply Short-Circuit Current
CFW11 0142 T 2	200 A	100 kA	160 A	254 x 914 x 660 mm	65 kA
CFW11 0180 T 2	200 A		200 A		
CFW11 0211 T 2	250 A		250 A		
CFW11 0105 T 4	125 A		125 A		
CFW11 0142 T 4	200 A		160 A		
CFW11 0180 T 4	200 A		200 A		
CFW11 0211 T 4	250 A		250 A		

3.2.3.2.1 IT Networks



ATTENTION!

In order to be able to use the frame size E CFW-11 inverter in IT networks (neutral conductor not grounded or grounded via a high ohmic value resistor) or in corner-grounded delta systems, it is necessary to remove the RFI filter capacitor and the MOV connected to the ground by changing the position of the J1 jumper on the PRT1 board from \oplus (XE1) to "NC", according to the [Figure 3.14 on page 3-18](#).

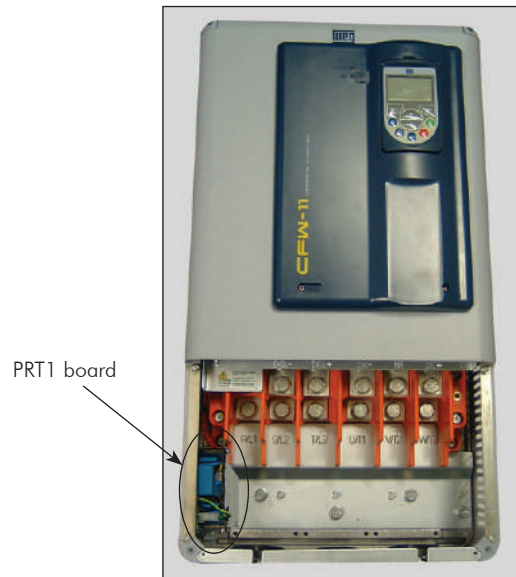

(a) Location of the PRT1 board (inverter without the bottom front cover)

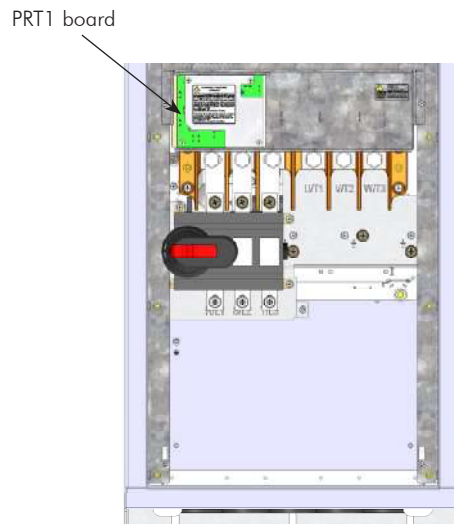

(b) Location of the PRT1 board for models with optional IP55

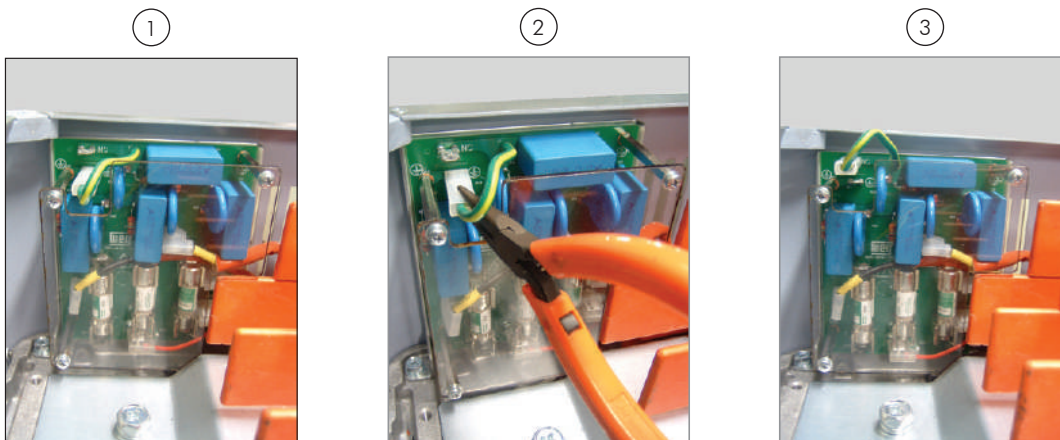

(c) Procedure for disconnecting the RFI filter and the MOV connected to the ground – necessary for using the inverter in IT or corner-grounded delta networks

Figure 3.14 - (a) to (c) - Location of the PRT1 board and procedure for disconnecting the RFI filter and the MOV connected to the ground – necessary for using the inverter in IT or corner-grounded delta networks

3.2.3.2.2 Command Fuses of Pre-Charge Circuit

- ☑ Besides the RFI filter capacitors and the MOV's, the PRT1 board also has 2 fuses for protecting the inverter command circuit.
- ☑ The PRT1 board location is presented in the [Figure 3.14 on page 3-18](#).
- ☑ The location of the PRT1 fuses is presented in the [Figure 3.14 on page 3-18](#).
- ☑ Specification of the command fuses:
 - Slow blow fuse 0.5 A / 600 V.
 - Manufacturer: Cooper Bussmann.
 - Part number: FNQ-R-1/2.
 - WEG part number: 10411493.

Consider the following items for the use of protection devices on the supply side of the inverter such as residual current devices or isolation monitors:

- ☑ The detection of a phase-to-ground short-circuit or an insulation fault shall be processed by the user, i.e., the user shall decide whether to indicate the fault and/or block the inverter operation.
- ☑ Contact the RCD manufacturer for selecting the most appropriate device to be used with inverters in order to avoid nuisance tripping due to the high frequency leakage currents that flow through the leakage capacitances of the inverter, cable, and motor system to the ground.

3.2.3.3 Dynamic Braking



ATTENTION!

For the CFW-11 frame size E models, only those with the DB option (CFW11XXXXTXODB) have the braking IGBT incorporated to the product.

The braking torque that can be obtained from the frequency inverter without braking resistors varies from 10 % to 35 % of the motor rated torque.

Braking resistors must be used to obtain higher braking torques. In this case, the energy regenerated in excess is dissipated in a resistor mounted externally to the inverter.

This type of braking is used in cases where short deceleration times are desired or when high inertia loads are driven.

The "Optimal Braking" feature may be used with the vector control mode, which eliminates in most cases the need of an external braking resistor.



NOTE!

Set P0151 and P0185 to their maximum values (400 V or 800 V) when using dynamic braking.

3.2.3.2.1 Sizing the Braking Resistor

The following application data shall be considered for the adequate sizing of the braking resistor:

- Desired deceleration time.
- Load inertia.
- Braking duty cycle.

In any case, the effective current value and the maximum braking current value presented in [Table 3.5 on page 3-20](#) shall be respected.

The maximum braking current defines the minimum braking resistor value in ohms.

The DC Link voltage level for the activation of the dynamic braking function is defined by parameter P0153 (dynamic braking level).

The power of the braking resistor is a function of the deceleration time, the load inertia, and the load torque.

For most applications, a braking resistor with the value in ohms indicated in [Table 3.5 on page 3-20](#) and the power of 20 % of the rated driven motor power. Use wire type resistors in a ceramic support with adequate insulation voltage and capable of withstanding high instantaneous power with respect to rated power. For critical applications with very short deceleration times and high inertia loads (ex.: centrifuges) or short duration cycles, consult WEG for the adequate sizing of the braking resistor.

Table 3.5 - Dynamic braking specifications

Inverter Model	Maximum Braking Current (I_{max}) [A]	Maximum Braking Power (peak value) (P_{max}) ⁽²⁾ [kW]	Effective Braking Current ($I_{effective}$) ⁽¹⁾ [A]	Dissipated Power (mean value) in the Braking Resistor (P_R) ⁽²⁾ [kW]	Recommended Resistor [Ω]	Power Wire Size (terminals DC+ and BR) ⁽³⁾ [mm ² (AWG)]
CFW110142T2O...DB...	266.7	106.7	142.0	30.2	1.5	70 (2/0) or 2 x 25 (2 x 4)
CFW110180T2O...DB...	266.7	106.7	180.0	48.6	1.5	120 (4/0) or 2 x 35 (2 x 2)
CFW110211T2O...DB...	333.3	133.3	211.0	53.4	1.2	150 (300) or 2 x 50 (2 x 1)
CFW110105T4O...DB...	186.0	148.8	105.0	47.4	4.3	50 (1)
CFW110142T4O...DB...	266.7	213.3	142.0	60.5	3.0	70 (2/0) or 2 x 25 (2 x 4)
CFW110180T4O...DB...	266.7	213.3	180.0	97.2	3.0	120 (4/0) or 2 x 35 (2 x 2)
CFW110211T4O...DB...	363.6	290.9	191.7	80.8	2.2	120 (250) or 2 x 50 (2 x 1)

(1) The effective braking current presented is just an indicative value, because it depends on the braking duty cycle. The effective braking current can be obtained from the equation below, where t_{br} is given in minutes and corresponds to the sum of all braking times during the most severe cycle of 5 (five) minutes.

$$I_{effective} = I_{max} \times \sqrt{\frac{t_{br}}{5}}$$

(2) The P_{max} and P_R values (maximum and mean power of the braking resistor respectively) presented are valid for the recommended resistors and for the effective braking currents presented in [Table 3.5 on page 3-20](#). The resistor power shall be changed according to the braking duty cycle.
 (3) For specifications on the recommended terminal type (bolt and tightening torque) for the connection of the braking resistor (terminals DC+ and BR), refer to the DC+ terminal specification at the [Table 3.2 on page 3-13](#).

3.2.3.2.2 Installation of the Braking Resistor

Install the braking resistor between the power terminals DC+ and BR.

Use twisted cable for the connection. Separate these cables from the signal and control cables. Size the cables according to the application, respecting the maximum and effective currents.

If the braking resistor is installed inside the inverter cabinet, consider its additional dissipated energy when sizing the cabinet ventilation.

Set parameter P0154 with the resistor value in ohms and parameter P0155 with the maximum resistor power in kW.



DANGER!

The inverter has an adjustable thermal protection for the braking resistor. The braking resistor and the braking transistor may damage if parameters P0153, P0154, and P0155 are not properly set or if the input voltage surpasses the maximum permitted value.



DANGER!

Le variateur possède une protection thermique réglable pour la résistance de freinage. La résistance de freinage et le transistor de freinage peuvent être endommagés si les paramètres P0153, P0154 et P0155 ne sont pas correctement définis ou si la tension d'entrée dépasse la valeur maximale autorisée.

The thermal protection offered by the inverter, when properly set, allows the protection of the resistor in case of overload; however, this protection is not guaranteed in case of braking circuitry failure. In order to avoid any damage to the resistor or risk of fire, install a thermal relay in series with the resistor and/or a thermostat in contact with the resistor body to disconnect the input power supply of the inverter, as presented in [Figure 3.15 on page 3-21](#).

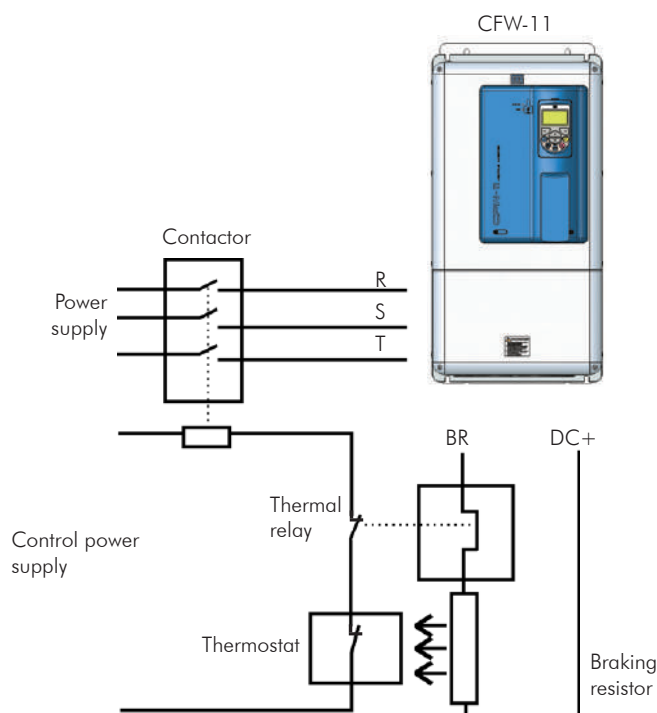

Figure 3.15 - Braking resistor connection



NOTE!

DC current flows through the thermal relay bimetal strip during braking.

3.2.3.4 Output Connections



ATTENTION!

The inverter has an electronic motor overload protection that shall be adjusted according to the driven motor. When several motors are connected to the same inverter, install individual overload relays for each motor.



ATTENTION!

The motor overload protection available at the CFW-11 is in accordance with the IEC60947-4-2 and UL508C standards, note the following information:

- Trip current equal to 1.25 times the motor rated current (P0401) adjusted in the oriented start-up menu.
- The parameter P0159 maximum setting (Motor Thermal Class) is 3 (Class 20).
- The parameter P0398 maximum setting (Motor Service Factor) is 1.15.



ATTENTION!

If a disconnect switch or a contactor is installed between the inverter and the motor, never operate them with a spinning motor or with voltage at the inverter output.

The characteristics of the cable used for the inverter and motor interconnection, as well as the physical location are extremely important to avoid electromagnetic interference in other equipment and to not affect the life cycle of motor windings and motor bearings controlled by inverters.

Recommendations for the motor cables:

Unshielded Cables:

- Can be used when it is not necessary to meet the European directive of electromagnetic compatibility (2004/108/EC).
- Keep motor cables away from other cables (signal cables, sensor cables, control cables, etc.), according to [Table 3.6 on page 3-23](#).
- The emission of the cables may be reduced by installing them inside a metal conduit, which shall be grounded at both ends.
- Connect a fourth cable between the motor ground and the inverter ground.



NOTE!

The magnetic field created by the current circulation in these cables may induce current in close metal pieces, heat them, and cause additional electrical losses. Therefore, keep the 3 (three) cables (U, V, W) always together.

Shielded Cables:

- ☑ They are mandatory when the electromagnetic compatibility directive (2004/108/EC) shall be met, as defined by the standard EN 61800-3 "Adjustable Speed Electrical Power Drive Systems". These cables act mainly by reducing the irradiated emission in the radio-frequency range.
- ☑ In reference to the type and details of installation, follow the recommendations of IEC 60034-25 "Guide for Design and Performance of Cage Induction Motors Specifically Designed for Converter Supply" – refer to a summary in [Figure 3.16 on page 3-23](#). Refer to the standard for further details and eventual modifications related to new revisions.
- ☑ Keep motor cables away from other cables (signal cables, sensor cables, control cables, etc.), according to [Table 3.6 on page 3-23](#).
- ☑ The grounding system shall be well interconnected among the several installation locations such as the grounding points of the motor and the inverter. Voltage difference or impedance between the several points may cause the circulation of leakage currents among the equipment connected to the ground, resulting in electromagnetic interference problems.

Table 3.6 - Minimum separation distance between motor cables and all other cables

Cable Length	Minimum Separation Distance
≤ 30 m (100 ft)	≥ 10 cm (3.94 in)
> 30 m (100 ft)	≥ 25 cm (9.84 in)

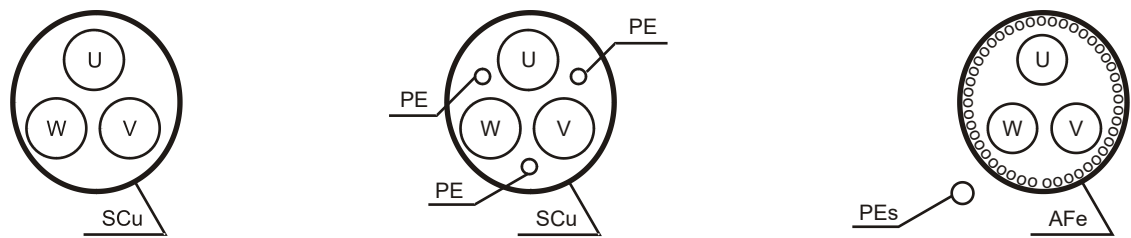

Symmetrical shielded cables: three concentric conductors with or without a ground conductor, symmetrically manufactured, with an external shield of copper or aluminum.

Notes:

- (1) SCu = copper or aluminum external shielding.
- (2) AFe = steel or galvanized iron.
- (3) PE = ground conductor.
- (4) Cable shielding shall be grounded at both ends (inverter and motor). Use 360° connections for a low impedance to high-frequencies. Refer to [Figure 3.17 on page 3-24](#).
- (5) For using the shield as a protective ground, it shall have at least 50 % of the power cables conductivity. Otherwise, add an external ground conductor and use the shield as an EMC protection.
- (6) Shielding conductivity at high-frequencies shall be at least 10 % of the power cables conductivity.

Figure 3.16 - Motor connection cables recommended by IEC 60034-25

- ☑ Connection of the motor cable shield to ground: make a connection with low impedance for high frequencies. Example in the [Figure 3.17 on page 3-24](#). In inverters without the Nema1 kit, connect the motor cable shield to the ground in a similar mode, with the clamp at the inverter inner part, according to the [Figure 3.17 on page 3-24](#).

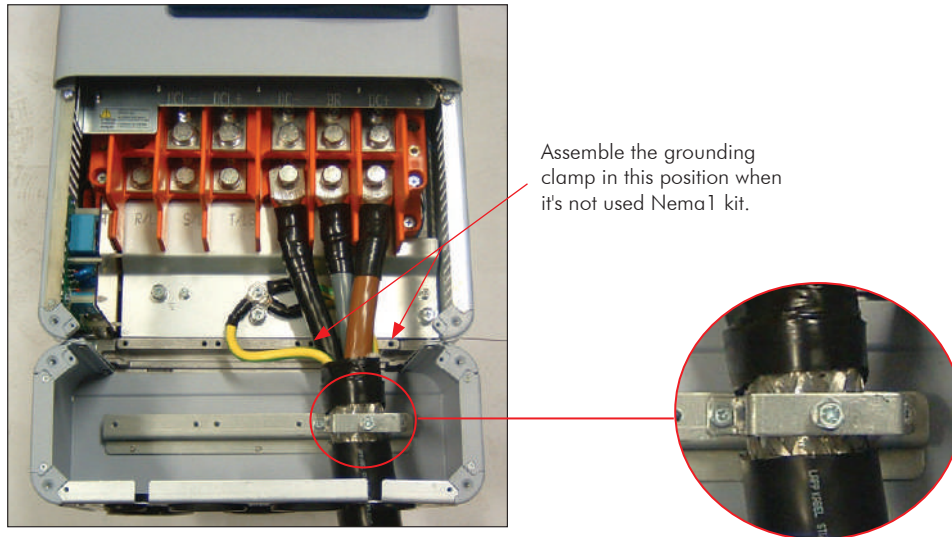

Figure 3.17 - Example of the motor cable shield connection at the inner part of the Nema1 kit supplied with the product

3.2.4 Grounding Connections



DANGER!

Do not share the grounding wiring with other equipment that operate with high currents (e.g. high power motors, soldering machines, etc.). When installing several inverters, follow the procedures presented in [Figure 3.18 on page 3-25](#) for the grounding connection.



DANGER!

Ne pas partager le câblage de mise à la terre avec d'autres équipements opérant avec des intensités élevées (par ex: moteurs haute puissance, postes de soudure, etc.). Lors de l'installation de plusieurs variateurs, appliquer les procédures présentées dans l'illustration 3.18 pour la connexion de mise à la terre.



ATTENTION!

The neutral conductor of the network must be solidly grounded; however, this conductor must not be used to ground the inverter.



DANGER!

The inverter must be obligatorily connected to a protective ground (PE).

Observe the following:

- Use a minimum wire gauge for grounding connection is provided in [Table 3.2 on page 3-13](#). Conform to local regulations and/or electrical codes in case a different wire gauge is required.
- Connect the inverter grounding connections to a ground bus bar, to a single ground point, or to a common grounding point (impedance $\leq 10 \Omega$).
- To comply with IEC 61800-5-1 standard, connect the inverter to the ground by using a single conductor copper cable with a minimum wire gauge of 10 mm², since the leakage current is greater than 3.5 mA AC.



DANGER!

Le variateur doit être raccordé à une terre de protection (PE).

Observer les règles suivantes:

- Utilisez la section minimale de raccordement à la terre indiquée dans le Tableau 3.2. Se conformer aux à la réglementation locale et/ou aux codes de l'électricité si une autre épaisseur de fil est nécessaire.
- Connectez la masse du variateur à une barre collectrice de terre en un seul point ou à un point commun de raccordement à la terre (impédance $\leq 10 \Omega$).
- Pour assurer la conformité avec la norme CEI 61800-5-1, connecter le variateur à la terre grâce à un câble en cuivre à un conducteur ayant une épaisseur de fil minimale de 10 mm², étant donné que le courant de fuite est supérieur à 3,5 mA C.A.

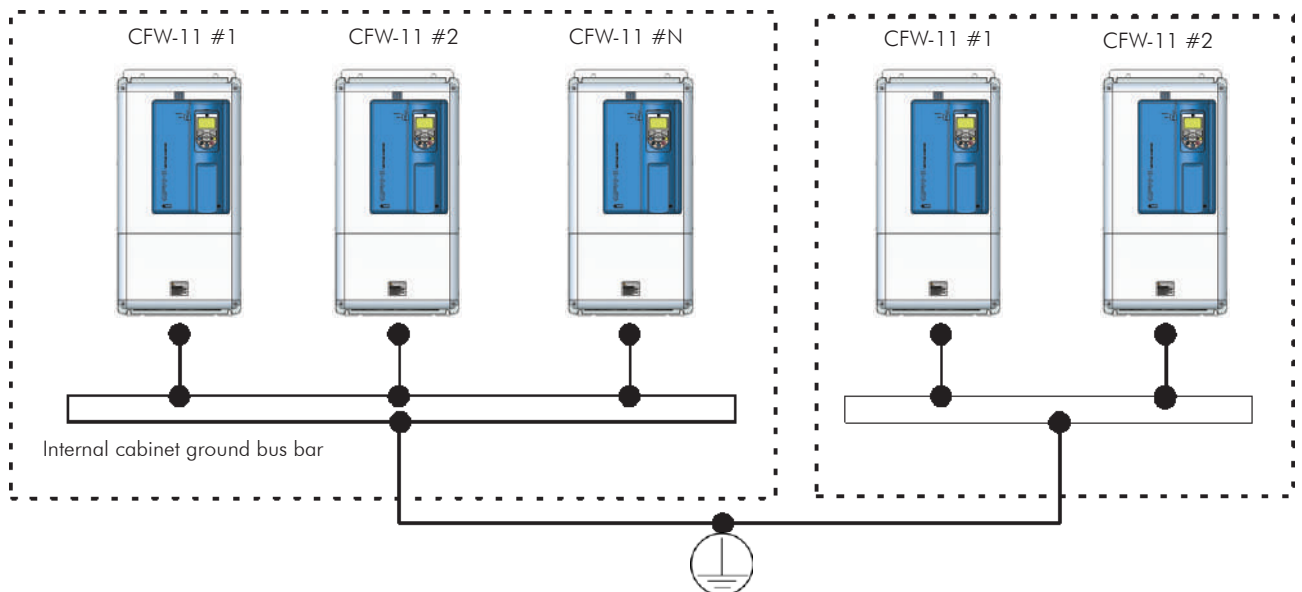

Figure 3.18 - Grounding connections with multiple inverters

3.2.5 Control Connections

The control connections (analog inputs/outputs, digital inputs/outputs), must be made at the CC11 control board terminal strip XC1.

Functions and typical connections are presented in [Figure 3.19 on page 3-27](#).

Installation and Connection

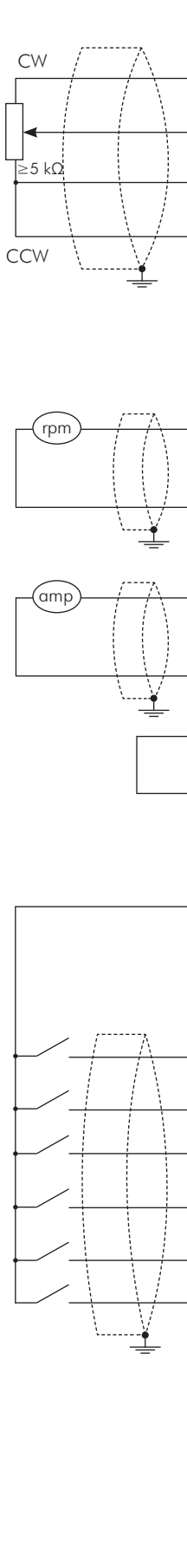

Connector XC1	Factory Default Function	Specifications
1	+REF	Positive reference for potentiometer Output voltage: +5.4 V, ±5 % Maximum output current: 2 mA
2	AI1+	Analog input 1: speed reference (remote) Differential Resolution: 12 bits Signal: 0 to 10 V ($R_{IN} = 400\text{ k}\Omega$) / 0 to 20 mA / 4 to 20 mA ($R_{IN} = 500\ \Omega$) Maximum voltage: ±30 V
3	AI1-	
4	REF-	Negative reference for potentiometer Output voltage: -4.7 V, ±5 % Maximum output current: 2 mA
5	AI2+	Analog input 2: no function Differential Resolution: 11 bits + signal Signal: 0 to ±10 V ($R_{IN} = 400\text{ k}\Omega$) / 0 to 20 mA / 4 to 20 mA ($R_{IN} = 500\ \Omega$) Maximum voltage: ±30 V
6	AI2-	
7	AO1	Analog output 1: speed Galvanic Isolation Resolution: 11 bits Signal: 0 to 10 V ($R_L \geq 10\text{ k}\Omega$) / 0 to 20 mA / 4 to 20 mA ($R_L \leq 500\ \Omega$) Protected against short-circuit
8	AGND (24 V)	Reference (0 V) for the analog outputs Connected to the ground (frame) through an impedance: 940 Ω resistor in parallel with a 22 nF capacitor. Same reference as the one of DGND *
9	AO2	Analog output 2: motor current Galvanic Isolation Resolution: 11 bits Signal: 0 to 10 V ($R_L \geq 10\text{ k}\Omega$) / 0 to 20 mA / 4 to 20 mA ($R_L \leq 500\ \Omega$) Protected against short-circuit
10	AGND (24 V)	Reference (0 V) for the analog outputs Connected to the ground (frame) through an impedance: 940 Ω resistor in parallel with a 22 nF capacitor. Same reference as the one of DGND *
11	DGND*	Reference (0 V) for the 24 Vdc power supply Connected to the ground (frame) through an impedance: 940 Ω resistor in parallel with a 22 nF capacitor. Same reference as the one of AGND (24 V)
12	COM	Common point of the digital inputs
13	24 Vdc	24 Vdc power supply 24 Vdc power supply, ±8 % Capacity: 500 mA Note: In the models with the 24 Vdc external control power supply (CFW11...O...W...) pin 13 of XC1 is considered as an input, that is, the user must provide a supply for the inverter (for further details refer to Item 7.1.5 24 Vdc External Control Power Supply on page 7-2 for more details). In all the other models this terminal is an output, i.e., the user has a 24 Vdc power supply available there
14	COM	Common point of the digital inputs
15	DI1	6 isolated digital inputs High level ≥ 18 V Low level ≤ 3 V Maximum input voltage = 30 V Input current: 11 mA @ 24 Vdc
16	DI2	
17	DI3	
18	DI4	
19	DI5	
20	DI6	
21	NC1	Digital output 1 DO1 (RL1): no fault Contact rating: Maximum voltage: 240 Vac Maximum current: 1 A NC - normally closed contact C - common NO - normally open contact
22	C1	
23	NO1	
24	NC2	
25	C2	
26	NO2	
27	NC3	
28	C3	
29	NO3	

(a) Digital inputs working as "Active High"

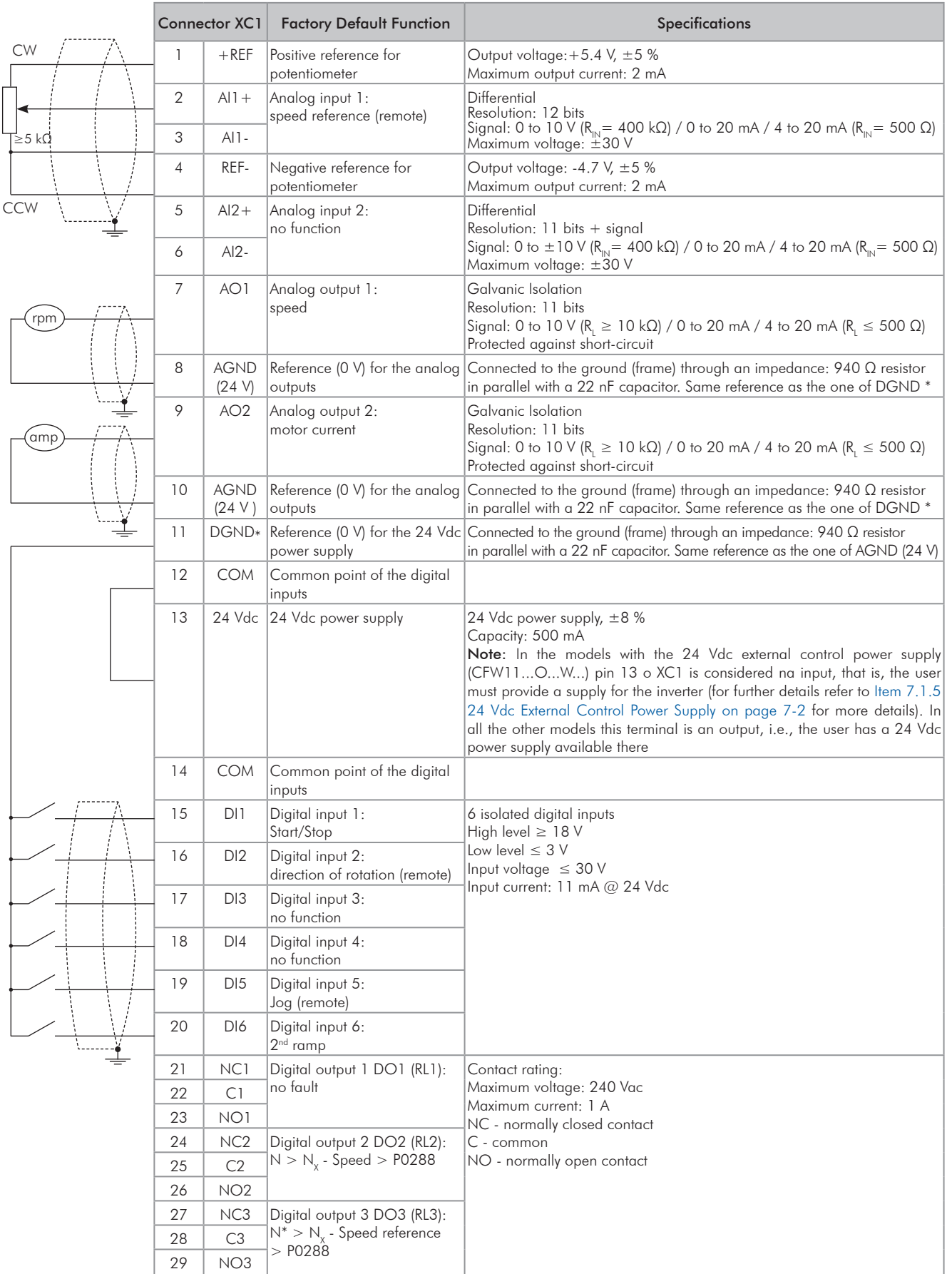

(b) Digital inputs working as "active low"

Figure 3.19 - (a) and (b) - Signals at connector XC1



NOTE!

In order to use the digital inputs as "active low", remove the jumper between XC1:11 and 12 and install it between XC1:12 and 13.

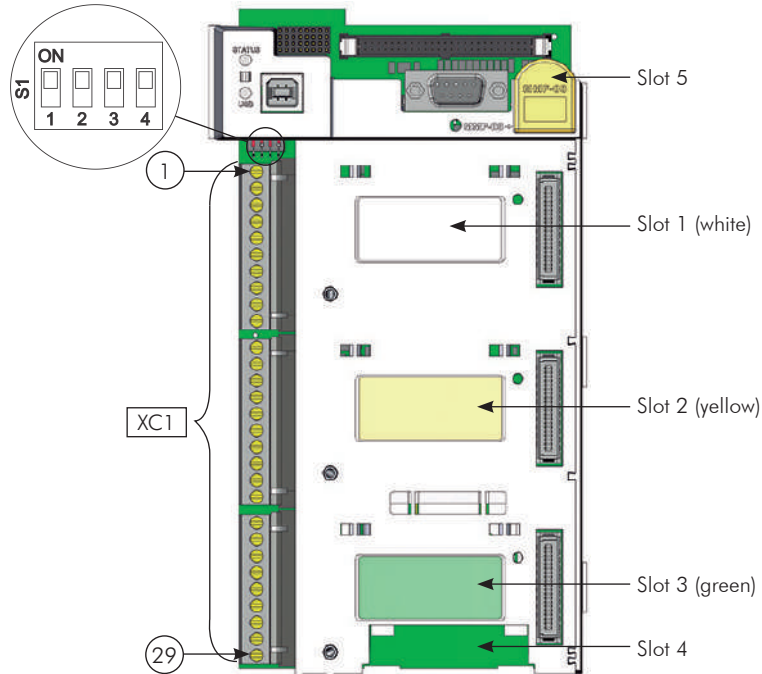

Figure 3.20 - Connector XC1 and DIP-switches for selecting the signal type of the analog inputs and outputs

The analog inputs and outputs are factory set to operate in the range from 0 to 10 V; this setting may be changed by using DIP-switch S1.

Table 3.7 - Configuration of DIP-switches for selecting the signal type of analog inputs and outputs

Signal	Factory Default Function	DIP-Switch	Selection	Factory Setting
AI1	Speed reference (remote)	S1.4	OFF: 0 to 10 V (factory setting) ON: 4 to 20 mA / 0 to 20 mA	OFF
AI2	No function	S1.3	OFF: 0 to ±10 V (factory setting) ON: 4 to 20 mA / 0 to 20 mA	OFF
AO1	Speed	S1.1	OFF: 4 to 20 mA / 0 to 20 mA ON: 0 to 10 V (factory setting)	ON
AO2	Motor current	S1.2	OFF: 4 to 20 mA / 0 to 20 mA ON: 0 to 10 V (factory setting)	ON

Parameters related to the analog inputs and outputs (AI1, AI2, AO1, and AO2) shall be programmed according to the DIP-switches settings and desired values.

Follow instructions below for the proper installation of the control wiring:

1. Wire gauge: 0.5 mm² (20 AWG) to 1.5 mm² (14 AWG).
2. Maximum tightening torque: 0.50 N.m (4.50 lbf.in).
3. Use shielded cables for the connections in XC1 and run the cables separated from the remaining circuits (power, 110 V / 220 Vac control, etc.), as presented in Table 3.6 on page 3-23. If control cables must cross other cables, it must be done perpendicularly among them, keeping a minimum of 5 cm (1.9 in) distance at the crossing point.

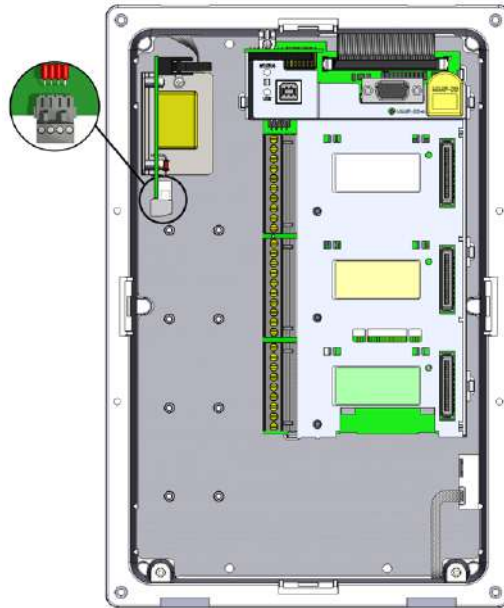

Frame size E inverters - SRB4.00 board

Figure 3.21 - SRBXX board connections (Safety Stop function)

Table 3.8 - Minimum separation distances between wiring

Cable Length	Minimum Separation Distance
≤ 30 m (100 ft)	≥ 10 cm (3.94 in)
> 30 m (100 ft)	≥ 25 cm (9.84 in)

- The adequate connection of the cable shield is shown in [Figure 3.22](#) on page 3-30. [Figure 3.23](#) on page 3-30 shows how to connect the cable shield to the ground.

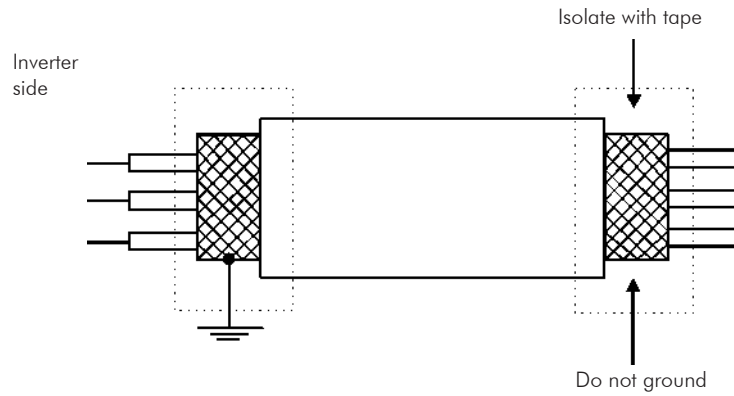

Figure 3.22 - Shield connection

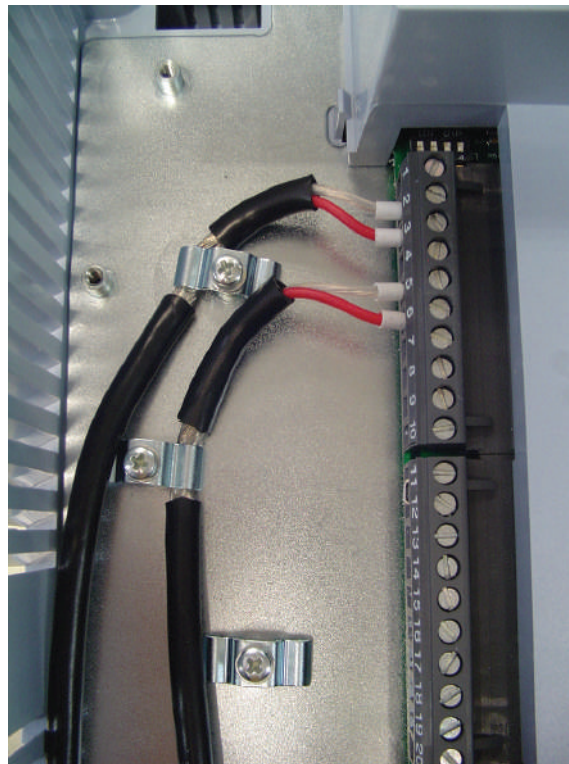

Figure 3.23 - Example of shield connection for the control wiring

5. Relays, contactors, solenoids or coils of electromechanical brakes installed close to the inverter may eventually create interferences in the control circuitry. To eliminate this effect, RC suppressors (with AC power supply) or free-wheel diodes (with DC power supply) must be connected in parallel to the coils of these devices.



3.2.6 Typical Control Connections

Control connection 1 - Run/Stop function controlled from the keypad (Local Mode).

With this control connection it is possible to run the inverter in local mode with the factory default settings. This operation mode is recommended for first-time users, since no additional control connections are required.

For the start-up in this operation mode, please follow instructions listed in [Chapter 5 FIRST TIME POWER-UP AND START-UP](#) on page 5-1.

Control connection 2 - 2 - Wire Start/Stop function (Remote Mode).

This wiring example is valid only for the default factory settings and if the inverter is set to remote mode. With the factory default settings, the selection of the operation mode (local/remote) is performed through the operator key  (local mode is default). Set P0220 = 3 to change the default setting of HMI key  to remote mode.

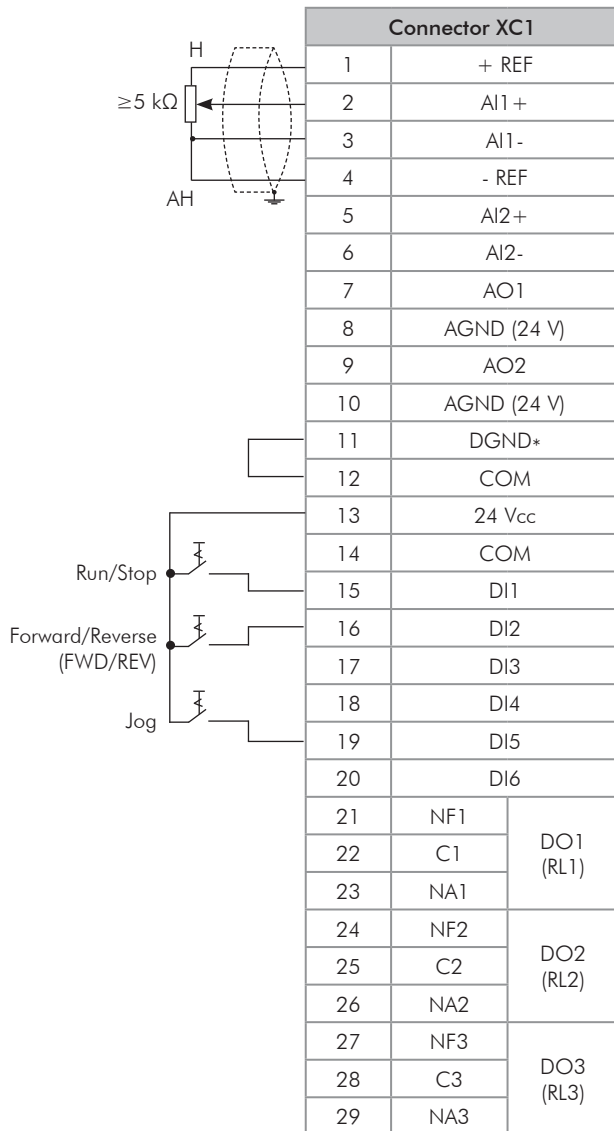

Figure 3.24 - XC1 wiring for control connection #2

Control connection 3 - 3 - Wire Start/Stop function.

Enabling the Start/Stop function with 3 Wire control.

Parameters to set:

Set DI3 to START

P0265 = 6

Set DI4 to STOP

P0266 = 7

Set P0224 = 1 (DIx) for 3 wire control in Local mode.

Set P0227 = 1 (DIx) for 3 wire control in Remote mode.

Set the Direction of Rotation by using digital input #2 (DI2).

Set P0223 = 4 to Local Mode or P0226 = 4 to Remote Mode.

S1 and S2 are Start (NO contact) and Stop (NC contact) push-buttons respectively.

The speed reference can be provided through the analog input (as in Control Connection #2), through the keypad (as in control connection #1) or through any other available source.

3

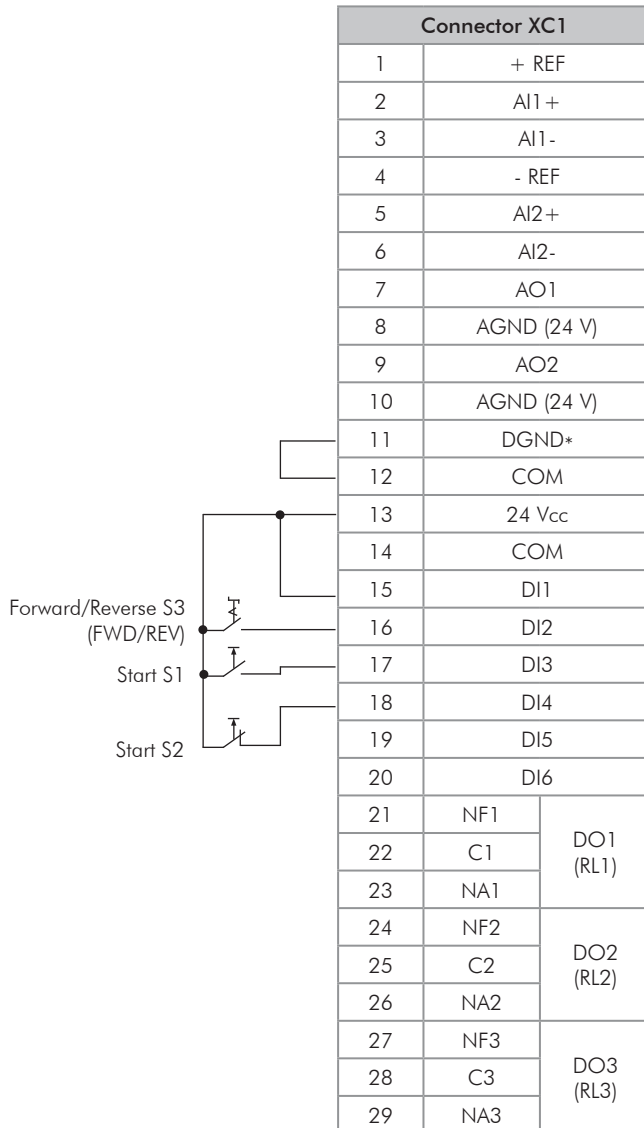

Figure 3.25 - XC1 wiring for control connection #3

Control connection 4 - Forward/Reverse.

Enabling the Forward/Reverse function.



Parameters to set:

Set DI3 to FORWARD

P0265 = 4

Set DI4 to REVERSE

P0266 = 5

When the Forward/Reverse function is set, it will be active either in Local or Remote mode. At the same time, the operator keys  and  will remain always inactive (even if P0224 = 0 or P0227 = 0).

The direction of rotation is determined by the Forward and Reverse inputs.

Clockwise to forward and counter-clockwise to reverse.

The speed reference can be provided by any source (as in control connection #3).

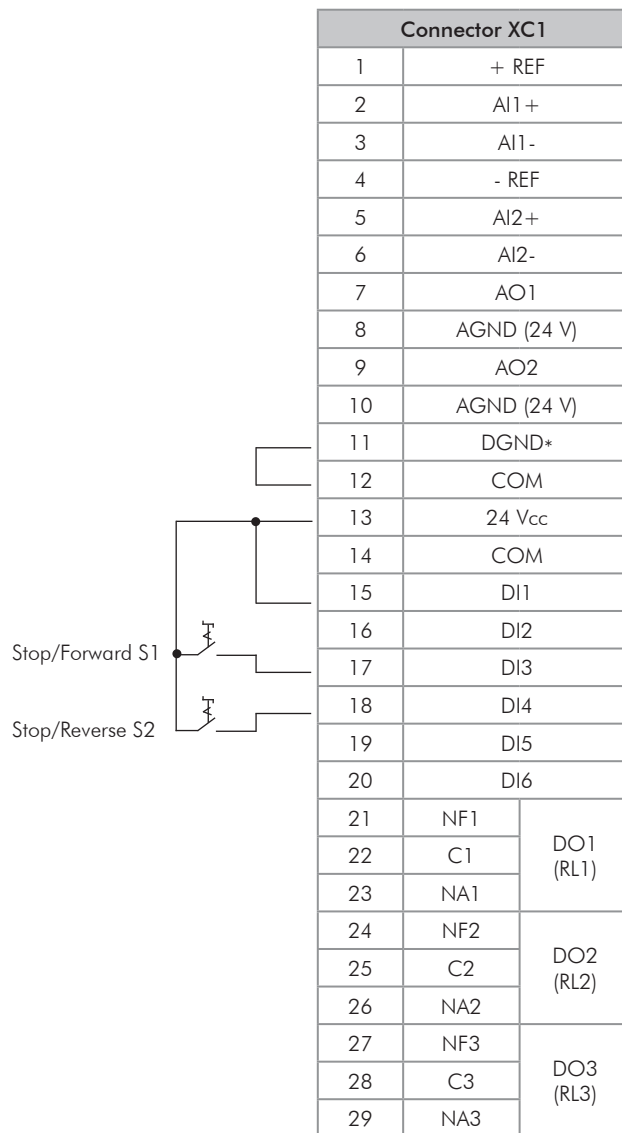

Figure 3.26 - XC1 wiring for control connection #4

3.3 SAFETY STOP FUNCTION

The inverters CFW11...O...Y... have the board SRBXX that implements Safety Stop function. Through this board it is possible to control two safety relays (K1 and K2) that actuate directly on the power circuit, more specifically on the IGBTs gate drivers power supply. The basic functional block diagram is shown in Figure 3.27 on page 3-34.

The safety relays guarantee that the IGBTs remain switched off when Safety Stop function is activated, even in case of an internal single failure. The position of SRBXX board and XC25 terminals (Safety Stop control terminals) on the inverter is shown in Figure 3.21 on page 3-29.

The Safety Stop function prevents the motor starting accidentally.

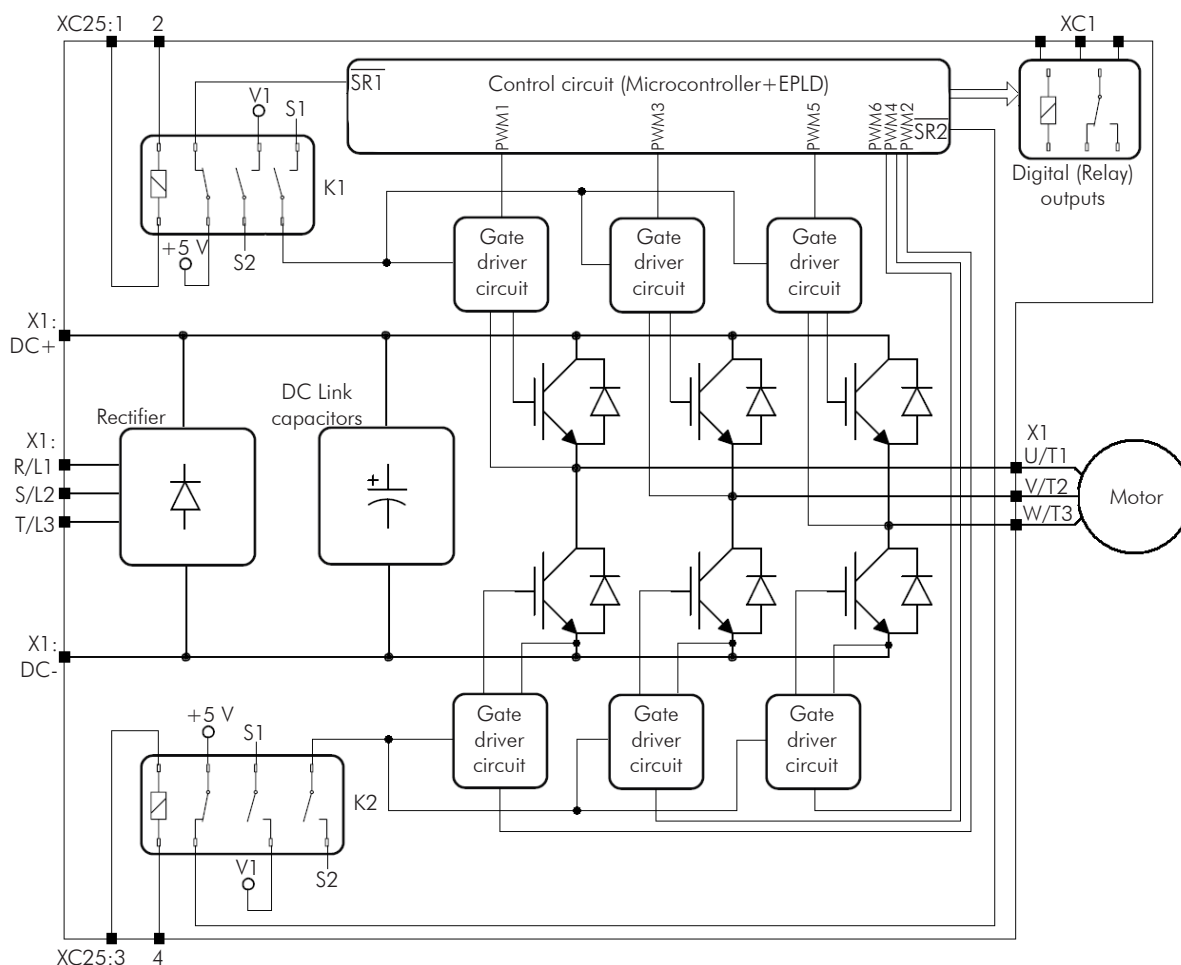

Note:
V1 = inverter internal voltage.

Figure 3.27 - Basic block diagram of Safety Stop function available in CFW-11 inverter series



DANGER!

The activation of the Safety Stop function does not guarantee electrical safety of the motor terminals (they are not isolated from the power supply in this condition).



DANGER!

L'activation de la fonction d'arrêt de sécurité ne garantit pas la sécurité électrique des bornes du moteur (elles ne sont pas isolées de l'alimentation électrique dans cet état).



ATTENTION!

In case of a multiple fault in the power stage of the inverter, the motor shaft can rotate up to 360/ (number of poles) degrees even with the activation of Safety Stop function. That must be considered in the application.



NOTE!

Inverter Safety Stop function is only one component of the safety control system of a machine and/or process. When inverter and its Safety Stop function is correctly used and with other safety components, it's possible to fulfill the requirements of standard EN 954-1 / ISO 13849-1, Category 3 (machine safety) and IEC/EN 61508, SIL2 (safety control/signaling applied to processes and systems).

The parameter P0029 shows if the inverter has identified correctly SRBXX board. See Bit 9 in [Table 3.9 on page 3-35](#) for details.

Table 3.9 - Content of P0029 parameter

Bits															
15	14	13	12	11	10	9	8	7	6	5	4	3	2	1	0
1	1	0	0 = with braking IGBT 1 = without braking IGBT	0	0 = control circuit is supplied from an external +24 Vdc power supply 1 = control circuit is fed by the inverter SMPS	0 = inverter without safety stop option 1 = inverter with Safety Stop option	0 = inverter without RFI filter 1 = inverter with RFI filter	Voltage rating of the inverter: 00 = 200...240 V 01 = 380...480 V 10 = 500...600 V 11 = 500...690 V or 660/690 V			Inverter output rated current				
Hexadecimal digit #4				Hexadecimal digit #3				Hexadecimal digit #2				Hexadecimal digit #1			

3.3.1 Installation



NOTE!

If the degree of protection of the used inverter is lower than IP54, it must be installed inside an IP54 (minimum) cabinet.

Table 3.10 - XC25 terminals (Safety Stop terminals) signals

XC25 Terminals	Function	Specifications
1	STO1	Terminal 1 of safety relay K1 coil
2	GND1	Terminal 2 of safety relay K1 coil
3	STO2	Terminal 1 of safety relay K2 coil
4	GND2	Terminal 2 of safety relay K2 coil



NOTE!

Terminals XC25: 2 and XC25: 4 are not internally connected to the reference of the inverter power supply +24 V. These terminals are often connected to the control terminal XC1:11.



NOTE!

Follow recommendations of [Item 3.2.5 Control Connections on page 3-25](#).

For XC25 control cabling considers the following:

- ☑ Use wire gauge from 0.5 mm² (20 AWG) to 1.5 mm² (14 AWG) and maximum tightening torque of maximum 0.50 N.m (4.50 lbf.in).
- ☑ Use shielded cables connected to ground only on inverter side. Use the provided metallic pieces as shown on [Figure 3.23 on page 3-30](#).
- ☑ Run the cables separated from the remaining circuits (power, 110 V / 220 Vac control, etc.).

3.3.2 Operation

3.3.2.1 Truth Table

Table 3.11 - Safety Stop function operation

STO1 Logic Level (Voltage Between XC25:1-2 Terminals)	STO2 Logic Level (Voltage Between XC25:3-4 Terminals)	Safety Stop Function	Inverter Behavior
0 (0 V)	0 (0 V)	Activated (enabled)	Inverter remains in STO state and does not accept commands. In order to escape this condition, it's required to have STO1 = 1 and STO2 = 1 simultaneously
0 (0 V)	1 (24 V)	Fault	Inverter is tripped by F160 fault (Safety Stop function related fault). To escape this condition, it's required to reset the inverter
1 (24 V)	0 (0 V)		
1 (24 V)	1 (24 V)	Disabled	Inverter accepts commands normally



NOTE!

Maximum delay between STO1 and STO2 signals: 100 ms (otherwise inverter will be tripped by F160 fault).

Safety Stop function takes priority over all other functions of the inverter.

This function should not be used as a control for starting and/or stopping the inverter.

3.3.2.2 State of Inverter, Fault and Alarm Related to Safety Stop Function

Table 3.12 - State of inverter, fault and alarm related to Safety Stop function

State/Fault/Alarm	Description	Cause
STO state	Safety Stop activated	Voltage between terminals 1 and 2 (relay K1 coil) and between terminals 3 and 4 (relay K2 coil) of XC25 lower than 17 V
F160 fault	Safety Stop function fault	It's applied voltage to relay K1 coil (STO1) but it's not applied voltage to relay K2 coil (STO2) or vice-versa or there is a delay of more than 100 ms between one signal and the other. To solve it, correct the external circuit that generates STO1 and STO2 signals

3.3.2.3 STO Status Indication

State of the inverter is shown on the left upper side of the display and in parameter P0006.

Possible states of the inverter: ready, run (inverter enabled), undervoltage, fault, self-tuning, configuration, DC braking and STO (Safety Stop function activated).

It's possible to set one or more digital and relay outputs of the inverter to indicate that Safety Stop function is activated (state of the inverter = STO), if the inverter is or not on a fault state and more specifically if the inverter was tripped by F160 fault (Safety Stop function fault). For that use the parameters P0275 (DO1), P0276 (DO2), P0277 (DO3), P0278 (DO4) and P0279 (DO5) according to [Table 3.13 on page 3-37](#).

Table 3.13 - P0275...P0279 options for indication of state of inverter or faults on DOx digital outputs

DOx Digital Output Function	Value to be Set on P0275...P0279	Comment
State of the inverter = STO (Safety Stop function activated)	33	Safety Stop function disabled: relay/transistor OFF Safety Stop function activated: relay/transistor ON
F160 fault (inverter tripped by Safety Stop function fault actuation)	34	Without F160 fault: relay/transistor OFF With fault F160: relay/transistor ON
Fault (inverter tripped by actuation of any fault)	13	Without fault: relay/transistor OFF With fault: relay/transistor ON
Without fault (state of the inverter is not fault)	26	With fault: relay/transistor OFF Without fault: relay/transistor ON

Refer to inverter programming manual for a complete list of options for parameters P0275...P0279.

3.3.2.4 Periodic Test

Safety Stop function, alternatively safety stop inputs (STO1 and STO2), must be activated at least once a year for preventive maintenance purposes. Inverter power supply must be switched off and then on again before carrying out this preventive maintenance. If during testing the power supply to the motor is not switched off, safety integrity is no longer assured for the Safety Stop function. The drive must therefore be replaced to ensure the operational safety of the machine or of the system process.

3.3.3 Examples of Wiring Diagrams of Inverter Control Signal

It is recommended to use inverter DI1 and DI2 digital inputs set as 3-wire start/stop commands and the wiring diagrams of inverter control signal according to Figure 3.28 on page 3-38.

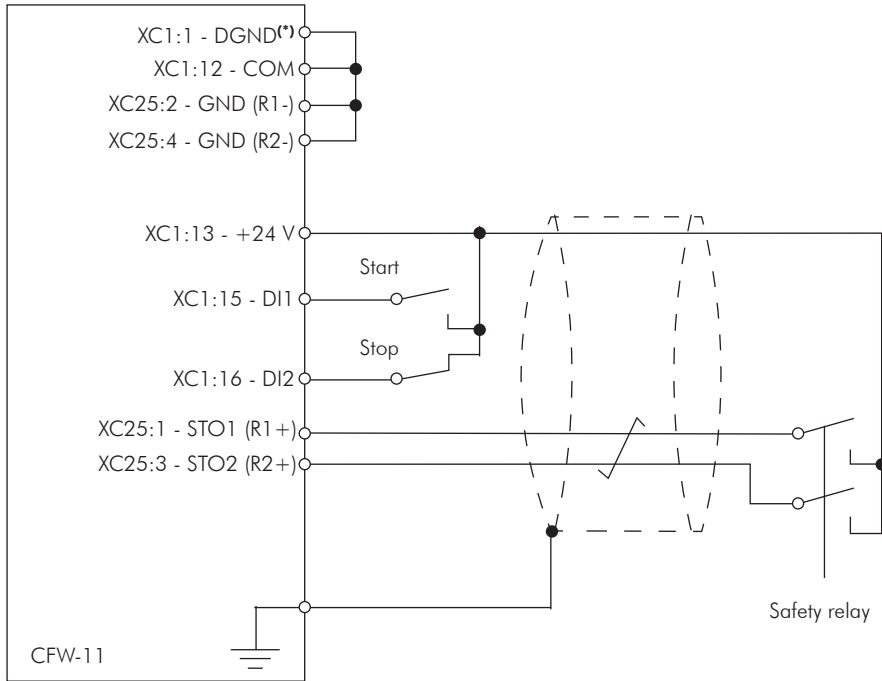

(a) STO or SS0 safety function (without an external safety relay)

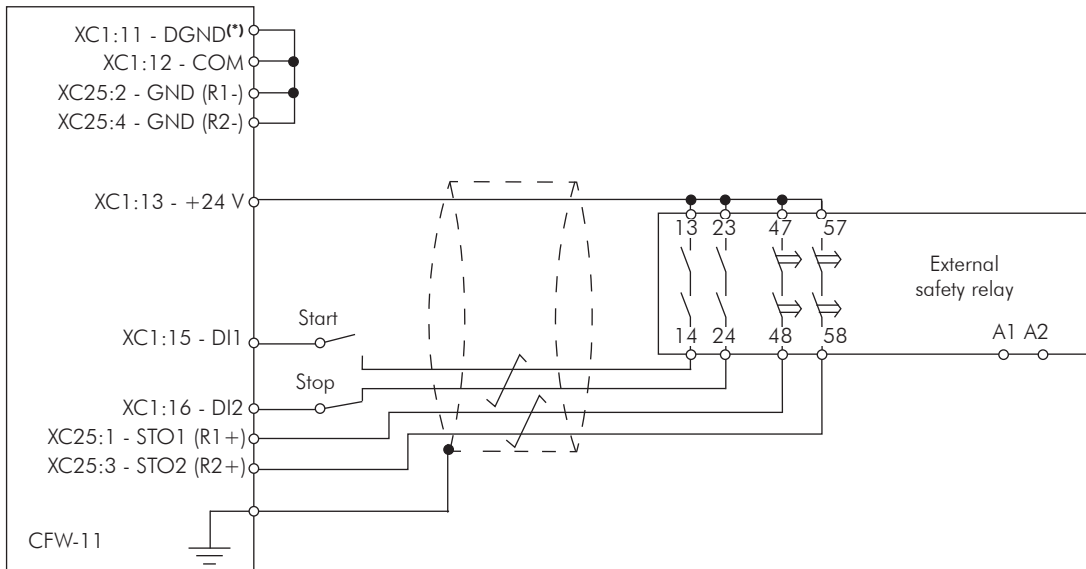

(b) SS1 safety function with an external safety relay (*)

Note:
 (*) For specifications of external safety relay, which is required to realize SS1 (stop category 1), refer to Item 3.3.4 Technical Specifications on page 3-39.

Figure 3.28 - (a) and (b) - Inverter control wiring examples (XC1 and XC25 terminals) to realize STO (or SS0, i.e., stop category 0) and SS1 (stop category 1) safety functions according to IEC/EN 61800-5-2 and IEC/EN 60204-1 standards - DI1 and DI2 inputs set as 3-wire start/stop commands

Circuit operation of SS1 function from Figure 3.28 on page 3-38:

In this case, when the activation command is given to the external safety relay, safety relay opens inverter DI2 signal (via terminals 23 to 24) and motor is decelerated first by the inverter (via deceleration ramp). When the time delay set at the external safety relay expires (this delay must be higher than required time to stop the motor, taking into account deceleration time set on the inverter and inertia of the motor load), the safety relay delayed contacts (terminals 47 to 48 and 57 to 58) opens inverter STO1 and STO2 signals and the inverter Safety Stop function is activated. The motor stops according to category 1 (SS1) of standard IEC/EN 60204-1.

In order to drive the motor again, it is required to apply STO1 and STO2 signals again (to close terminals 13 to 23 and 23 to 24) and apply a pulse on inverter DI1 input (START).

3.3.4 Technical Specifications

3.3.4.1 Electrical Control Characteristics

Safety Stop function inputs	XC25:1-2, XC25:3-4	2 independent inputs for Safety Stop function Power supply: 24 Vdc (max. 30 V) Impedance: 960 Ω State 0 if < 2 V, state 1 if > 17 V
External safety relay specifications (only when SS1 function is required according to IEC/EN 61800-5-2 and IEC/EN 60204-1 standards) refer to Figure 3.28 on page 3-38	General requirements	IEC 61508 and/or EN 954-1 and/or ISO 13849-1
	Output requirements	Number of current paths: 2 independent paths (one for each STO path) Switching voltage capability: 30 Vdc per contact Switching current capability: 100 mA per contact Maximum switching delay between contacts: 100 ms
	Example	Type/manufacturer: WEG/ Instrutech CPI-D

3.3.4.2 Operational Safety Characteristics

Protection	Of the machine	Safety Stop function which forces stopping and/or prevents the motor from restarting unintentionally, conforming to EN 954-1 / ISO 13849-1 category 3, IEC/EN 61800-5-2 and IEC/EN 60204-1
	Of the system process	Safety Stop function which forces stopping and/or prevents the motor from restarting unintentionally, conforming to IEC/EN 61508 level SIL2 and IEC/EN 61800-5-2

3.4 INSTALLATION ACCORDING TO THE EUROPEAN DIRECTIVE OF ELECTROMAGNETIC COMPATIBILITY

The frame size E CFW-11 inverters have an internal RFI filter for the reduction of the electromagnetic interference. These inverters, when properly installed, meet the requirements of the electromagnetic compatibility directive – "EMC Directive 2004/108/EC".

The CFW-11 inverter series has been designed only for industrial applications. Therefore, the emission limits of harmonic currents defined by the standards EN 61000-3-2 and EN 61000-3-2/A14 are not applicable.



ATTENTION!

Do not use inverters with internal RFI filters in IT networks (neutral is not grounded or grounding provided by a high ohm value resistor) or in grounded delta networks ("delta corner earthed"), because these type of networks damage the filter capacitors of the inverter.

3.4.1 Conformal Installation

For the conformal installation use:

1. J1 cable in the position \oplus (XE1). Refer to [Item 3.2.3.2.1 IT Networks on page 3-17](#).
2. a) Shielded output cables (motor cables) with the shield connected at both ends, motor and inverter, by means of a low impedance to high frequencies connection.

Use the clamps supplied with the product, making sure there is a good contact between the shield and that clamp.

Keep the separation distance to the other cables according to the [Table 3.6 on page 3-23](#) indication.

Refer to the [Item 3.2.3 Power Connections on page 3-16](#), for more information.

Maximum motor cable length and conducted and radiated emission levels according to the [Figure 3.15 on page 3-21](#).

If a lower conducted emission level category is wished, then an external RFI filter must be used at the inverter input. For more information (RFI filter commercial reference, motor cable length and emission levels) refer to the [Table 3.15 on page 3-42](#).

- b) As a second option only for the V/f and VVW control modes when using a sinusoidal output filter: Adjust the switching frequency in 5 or 10 kHz (P0297 = 2 or 3) and the parameter P0350 in 2 or 3 (not allowing the automatic reduction of the switching frequency to 2.5 kHz). Refer to [Table 8.2 on page 8-3](#) to [Table 8.5 on page 8-4](#) for output current specification for 5 kHz and 10 kHz. Output cables (motor cables) that are not shielded can be used, provided that RFI filters are installed at the inverter input and output, as presented in the [Table 3.16 on page 3-43](#). The maximum motor cable length and the emission levels for each configuration are also presented. Keep the separation from the other cables according to the [Table 3.8 on page 3-29](#). Refer to the [Item 3.2.3 Power Connections on page 3-16](#) for more information. The filters presented in [Table 3.16 on page 3-43](#) were defined for the operation of the inverter at 5 kHz switching frequency and rated output current as shown in [Table 8.2 on page 8-3](#) and [Table 8.3 on page 8-3](#). Those filters can also be used for 10 kHz, however they are not optimized for it. In order to optimize them for use with the inverter at 10 kHz, refer to the [Table 8.4 on page 8-4](#) and [Table 8.5 on page 8-4](#).

3. Use shielded control cables, keeping them separate from the other cables as described in [Item 3.2.5 Control Connections on page 3-25](#).
4. Inverter grounding according to the instructions on [Item 3.2.4 Grounding Connections on page 3-24](#).

3.4.2 Standard Definitions

IEC/EN 61800-3: "Adjustable Speed Electrical Power Drives Systems"

- Environment:

First Environment: includes domestic premises. It also includes establishments directly connected without intermediate transformer to a low-voltage power supply network which supplies buildings used for domestic purposes. Example: houses, apartments, commercial installations, or offices located in residential buildings.

Second Environment: includes all establishments other than those directly connected to a low-voltage power supply network which supplies buildings used for domestic purposes.

Example: industrial area, technical area of any building supplied by a dedicated transformer.

- Categories:

Category C1: inverters with a voltage rating less than 1000 V and intended for use in the First Environment.

Category C2: inverters with a voltage rating less than 1000 V, intended for use in the First Environment, not provided with a plug connector or a movable installations, and installed and commissioned by a professional.

Note: A professional is a person or organization familiar with the installation and/or commissioning of inverters, including the EMC aspects.

Category C3: inverters with a voltage rating less than 1000 V and intended for use in the Second Environment only (not designed for use in the First Environment).

Category C4: inverters with a voltage rating equal to or greater than 1000 V, or with a current rating equal to or greater than 400 Amps, or intended for use in complex systems in the Second Environment.

EN 55011: "Threshold values and measuring methods for radio interference from industrial, scientific and medical (ISM) high-frequency equipment"

Class B: equipment intended for use in the low-voltage power supply network (residential, commercial, and light-industrial environments).

Class A1: equipment intended for use in the low-voltage power supply network. Restricted distribution.

Note: Must be installed and commissioned by a professional when applied in the low-voltage power supply network.

Class A2: equipment intended for use in industrial environments.

3.4.3 Emission and Immunity Levels

Table 3.14 - Emission and immunity levels

EMC Phenomenon	Basic Standard	Level
Emission:		
Mains terminal disturbance voltage Frequency range: 150 kHz to 30 MHz	IEC/EN61800-3 (2004) + A1 (2011)	It depends on the inverter model and on the motor cable length. Refer to Table 3.15 on page 3-42
Electromagnetic radiation disturbance Frequency range: 30 MHz to 1000 MHz		
Immunity:		
Electrostatic discharge (ESD)	IEC 61000-4-2 (2008)	4 kV for contact discharge and 8 kV for air discharge
Fast transient-burst	IEC 61000-4-4 (2012)	2 kV / 5 kHz (coupling capacitor) power input cables 1 kV / 5 kHz control cables, and remote keypad cables 2 kV / 5 kHz (coupling capacitor) motor output cables
Conducted radio-frequency common mode	IEC 61000-4-6 (2013)	0.15 to 80 MHz; 10 V; 80 % AM (1 kHz) Motor cables, control cables, and remote keypad cables
Surge immunity	IEC 61000-4-5 (2014)	1.2/50 μ s, 8/20 μ s 1 kV line-to-line coupling 2 kV line-to-ground coupling
Radio-frequency electromagnetic field	IEC 61000-4-3 (2010)	80 MHz to 1000 GHz 10 V/m 1,4 GHz to 2 GHz 3 V/m 2 GHz to 2,7 GHz 1 V/m 80 % AM (1 kHz)

Table 3.15 - Conducted and radiated emission levels

Inverter Model (With Built-in RFI Filter)	Without External RFI Filter		With External RFI filter		
	Conducted Emission - Maximum Motor Cable Length	Radiated Emission - without Metallic Cabinet	External RFI Filter Part Number - (Manufacturer: EPCOS)	Conducted Emission - Maximum Motor Cable Length	Radiated Emission - with Metallic Cabinet
	Category C3	Category		Category C2	Category
CFW11 0142 T 2	100 m (330 ft)	C3 ⁽¹⁾	B84143B0150S020	100 m (330 ft)	C2
CFW11 0180 T 2	100 m (330 ft)	C3 ⁽¹⁾	B84143B0180S020 ⁽¹⁾	100 m (330 ft)	C2
CFW11 0211 T 2	100 m (330 ft)	C3 ⁽¹⁾	B84143B0250S020 ⁽²⁾	100 m (330 ft)	C2
CFW11 0105 T 4	100 m (330 ft)	C3 ⁽¹⁾	B84143B0150S020	100 m (330 ft)	C2
CFW11 0142 T 4	100 m (330 ft)	C3 ⁽¹⁾	B84143B0150S020	100 m (330 ft)	C2
CFW11 0180 T 4	100 m (330 ft)	C3 ⁽¹⁾	B84143B0180S020 ⁽¹⁾	100 m (330 ft)	C2
CFW11 0211 T 4	100 m (330 ft)	C3 ⁽¹⁾	B84143B0250S020 ⁽²⁾	100 m (330 ft)	C2

(1) For inverter/filter surrounding air temperature higher than 40 °C (104 °F) and continuous output current higher than 172 Arms, it's required to use B84143B0250S020 filter.

(2) For inverter/filter surrounding air temperature of 40 °C (104 °F) and HD applications (heavy duty cycle, output current < 180 Arms), it's possible to use B84143B0180S020 filter.

Table 3.16 - Required RFI filters for unshielded motor cable installations and further information on conducted and radiated levels

Inverter Model (with built-in RFI filter)	Inverter Duty Cycle	External RFI Filters Part Number (manufacturer: EPCOS)				Conducted Emission - Maximum Motor Cable Length	Radiated Emission - Category	
		Surrounding Air Temperature = 45 °C (113 °F)		Surrounding Air Temperature = 40 °C (104 °F)			Category C1	Without Metallic Cabinet
		Inverter Input	Inverter Output ⁽¹⁾	Inverter Input	Inverter Output ⁽¹⁾			
CFW11 0142 T 2	ND	B84143-D150-R127	B84143-V180-R127	B84143-D150-R127	B84143-V180-R127	300 m (984.2 ft)	C2	C2
	HD	B84143-D120-R127	B84143-V180-R127	B84143-D120-R127	B84143-V180-R127			
CFW11 0180 T 2	ND	B84143-D200-R127	B84143-V180-R127	B84143-D200-R127	B84143-V180-R127	300 m (984.2 ft)	C2	C2
	HD	B84143-D150-R127	B84143-V180-R127	B84143-D150-R127	B84143-V180-R127			
CFW11 0211 T 2	ND	B84143-D200-R127	B84143-V320-R127	B84143-D200-R127	B84143-V320-R127	300 m (984.2 ft)	C2	C2
	HD	B84143-D200-R127	B84143-V180-R127	B84143-D200-R127	B84143-V180-R127			
CFW11 0105 T 4	ND	B84143-D90-R127	B84143-V95-R127	B84143-D90-R127	B84143-V95-R127	300 m (984.2 ft)	C2	C2
	HD	B84143-D75-R127	B84143-V95-R127	B84143-D75-R127	B84143-V95-R127			
CFW11 0142 T 4	ND	B84143-D120-R127	B84143-V180-R127	B84143-D120-R127	B84143-V180-R127	300 m (984.2 ft)	C2	C2
	HD	B84143-D90-R127	B84143-V95-R127	B84143-D120-R127	B84143-V180-R127			
CFW11 0180 T 4	ND	B84143-D150-R127	B84143-V180-R127	B84143-D150-R127	B84143-V180-R127	300 m (984.2 ft)	C2	C2
	HD	B84143-D120-R127	B84143-V180-R127	B84143-D120-R127	B84143-V180-R127			
CFW11 0211 T 4	ND	B84143-D200-R127	B84143-V180-R127	B84143-D200-R127	B84143-V320-R127	300 m (984.2 ft)	C2	C2
	HD	B84143-D150-R127	B84143-V180-R127	B84143-D150-R127	B84143-V180-R127			

(1) The output filter is of the sinusoidal type, i.e., the motor voltage waveform is approximately sinusoidal, not pulsed as in the applications without this filter.

4 HMI

This chapter are described the following information:

- ☑ The operator keys and their functions.
- ☑ The indications on the display.
- ☑ Parameter structure.



4.1 INTEGRAL KEYPAD - HMI-CFW11

The integral keypad can be used to operate and program (view/edit all parameters) of the CFW-11 inverter.

The inverter keypad navigation is similar to the one used in cell phones and the parameters can be accessed in numerical order or through groups (Menu).

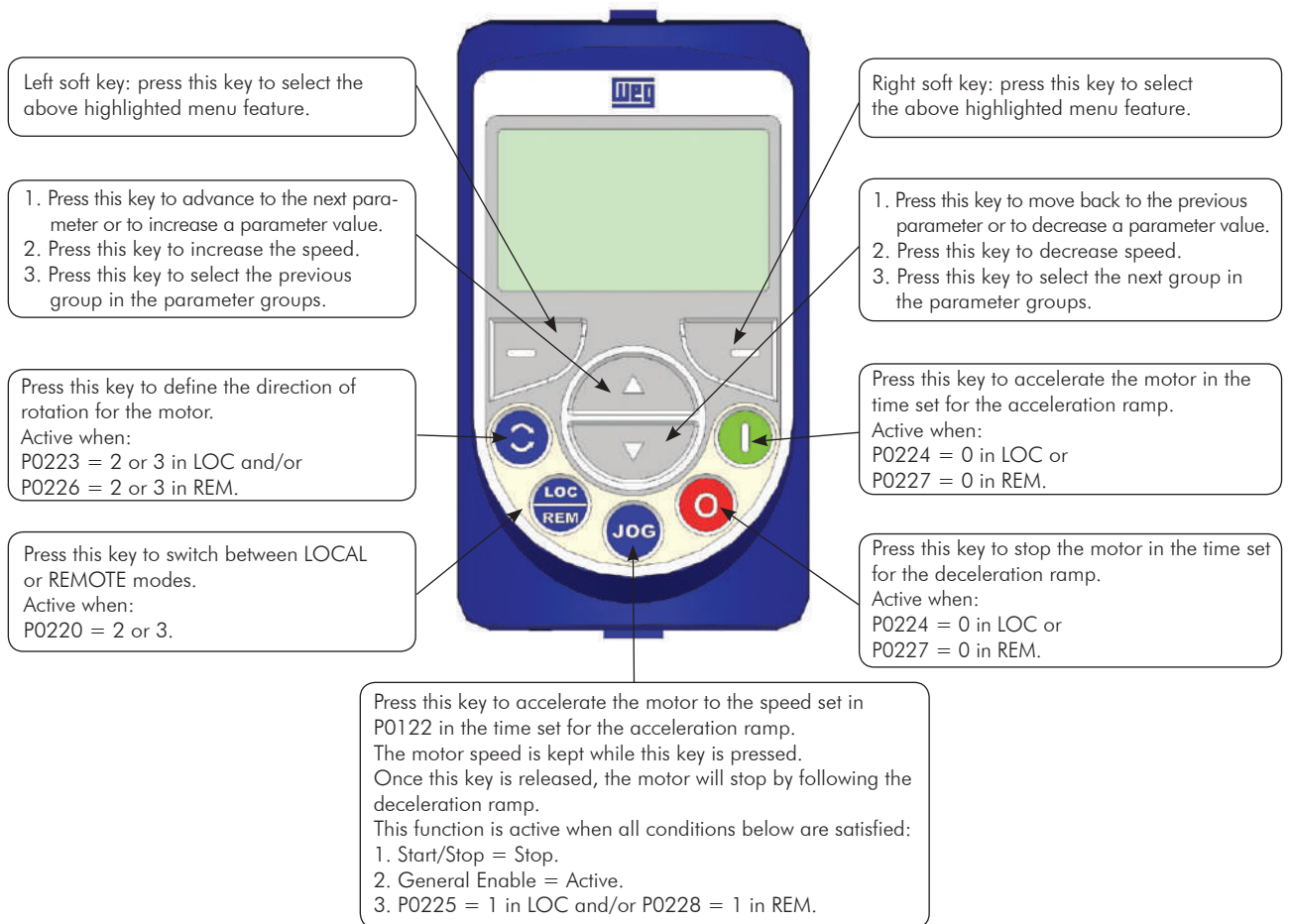

Figure 4.1 - Operator keys

Battery:



NOTE!

The battery is necessary only to keep the internal clock operation when the inverter stays without power. If the battery is completely discharged or if it is not installed in the keypad, the displayed clock time will be invalid and an alarm condition "A181 - Invalid clock time" will be indicated whenever the AC power is applied to the inverter.

The battery life expectancy is of approximately 10 years. When necessary, replace the battery by another of the CR2032 type.



Cover for battery access



Press the cover and rotate it counterclockwise



Remove the cover



Remove the battery with the help of a screwdriver positioned in the right side



HMI without the battery



Install the new battery positioning it first at the left side



Press the battery for its insertion



Put the cover back and rotate it clockwise

Figure 4.2 - HMI battery replacement



NOTE!

At the end of the battery useful life, please do not discard batteries in your waste container, but use a battery disposal site.

Installation:

- ☑ The keypad can be installed or removed from the inverter with or without AC power applied to the inverter.
- ☑ The HMI supplied with the product can also be used for remote command of the inverter. In this case, use a cable with male and female D-Sub9 (DB-9) connectors wired pin to pin (mouse extension type) or a market standard Null-Modem cable. Maximum length of 10 m (33 ft). It is recommended the use of the M3 x 5.8 standoffs supplied with the product. Recommended torque: 0.5 N.m (4.5 lbf.in).

When power is applied to the inverter, the display automatically enters the monitoring mode. [Figure 4.3 on page 4-3](#) presents the monitoring screen displayed for the factory default settings. By properly setting specific inverter parameters, other variables can be displayed in the monitoring mode or the value of a parameter can be displayed using bar graphs or with larger characters as presented in [Figure 4.3 on page 4-3](#).

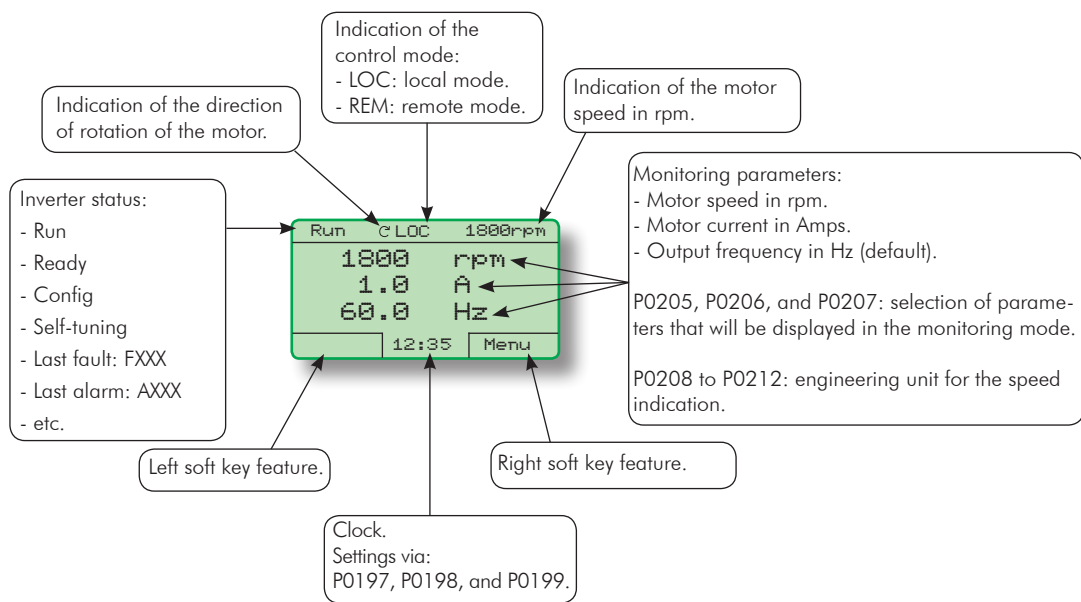

(a) Monitoring screen with the factory default settings

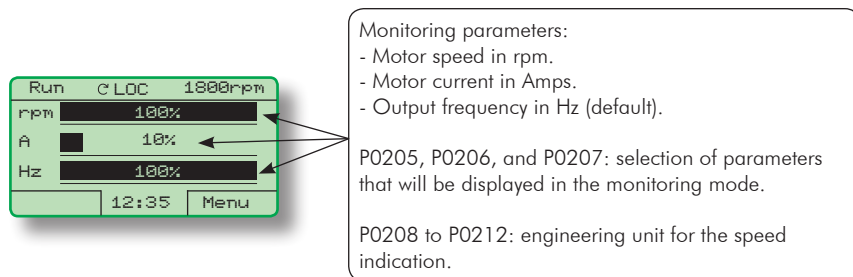

(b) Example of a monitoring screen with bar graphs

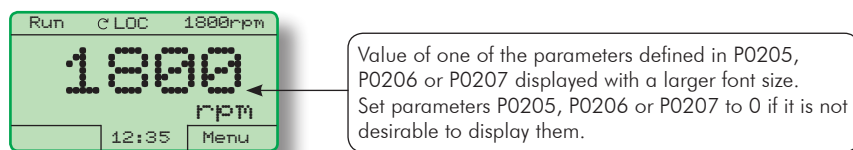

(c) Example of a monitoring screen displaying a parameter with a larger font size

Figure 4.3 - (a) to (c) - Keypad monitoring modes

4.2 PARAMETERS ORGANIZATION

When the right soft key ("MENU") is pressed in the monitoring mode, the display shows the first 4 groups of parameters. An example of how the groups of parameters are organized is presented in [Table 4.1 on page 4-4](#). The number and name of the groups may change depending on the firmware version used. For further details on the existent groups for the firmware version used, please refer to the programming manual.

Table 4.1 - Groups of parameters

Level 0	Level 1	Level 2		Level 3				
Monitoring	00	ALL PARAMETERS						
	01	PARAMETER GROUPS	20	Ramps				
			21	Speed References				
			22	Speed Limits				
			23	V/f Control				
			24	Adjust. V/f Curve				
			25	VVW Control				
			26	V/f Current Limit.				
			27	V/f DC Volt. Limit.				
			28	Dynamic Braking				
			29	Vector Control	90	Speed Regulator		
					91	Current Regulator		
					92	Flux Regulator		
					93	I/F Control		
					94	Self-Tuning		
					95	Torque Curr. Limit.		
					96	DC Link Regulator		
			30	HMI				
			31	Local Command				
			32	Remote Command				
			33	3-Wire Command				
			34	FWD/REV Run Comm.				
			35	Zero Speed Logic				
			36	Multispeed				
			37	Electr. Potentiom.				
			38	Analog Inputs				
			39	Analog Outputs				
			40	Digital Inputs				
			41	Digital Outputs				
			42	Inverter Data				
			43	Motor Data				
	44	FlyStart/RideThru						
	45	Protections						
	46	PID Regulator						
	47	DC Braking						
	48	Skip Speed						
	49	Communication	110	Local/Rem Config.				
			111	Status/Commands				
			112	CANopen/DeviceNet				
			113	Serial RS232/485				
			114	Anybus				
			115	Profibus DP				
	50	SoftPLC						
	51	PLC						
	52	Trace Function						
	02	ORIENTED START-UP						
	03	CHANGED PARAMETERS						
04	BASIC APPLICATION							
05	SELF-TUNING							
06	BACKUP PARAMETERS							
07	I/O CONFIGURATION	38	Analog Inputs					
		39	Analog Outputs					
		40	Digital Inputs					
		41	Digital Outputs					
08	FAULT HISTORY							
09	READ ONLY PARAMS.							

5 FIRST TIME POWER-UP AND START-UP

This chapter describes how to:

- Check and prepare the inverter before power-up.
- Power-up the inverter and check the result.
- Set the inverter for the operation in the V/f mode based on the power supply and motor information by using the Oriented Start-Up routine and the Basic Application group.

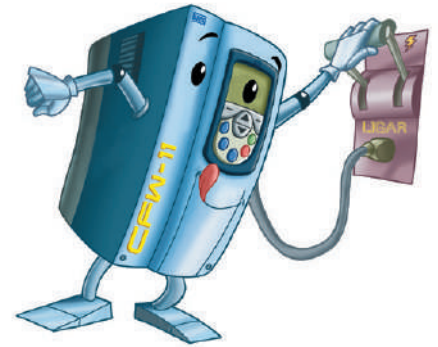

NOTE!

For a detailed description of the VVW or Vector control modes and for other available functions, please refer to the CFW-11 programming manual.

5.1 PREPARE FOR START-UP

The inverter shall have been already installed according to the recommendations listed in [Chapter 3 INSTALLATION AND CONNECTION on page 3-1](#). The following recommendations are applicable even if the application design is different from the suggested control connections.



DANGER!

Always disconnect the main power supply before performing any inverter connection.



DANGER!

Débranchez toujours l'alimentation principale avant d'effectuer une connexion sur le variateur.

1. Check if power, grounding, and control connections are correct and firmly secured.
2. Remove from the inside of the inverter all installation material left behind.
3. Verify the motor connections and if the motor voltage and current is within the rated value of the inverter.
4. Mechanically uncouple the motor from the load:
If the motor cannot be uncoupled, make sure that the chosen direction of rotation (forward or reverse) will not result in personnel injury and/or equipment damage.
5. Return the inverter covers.
6. Measure the power supply voltage and verify if it is within the allowed range, according to the [Chapter 8 TECHNICAL SPECIFICATIONS on page 8-1](#).
7. Apply power to the input:
Close the input disconnect switch.
8. Check the result of the first time power-up:
The keypad should display the standar monitoring mode ([Figure 4.3 on page 4-3](#)) and the status LED should be steady green.

5.2 START-UP

The start-up procedure for the V/f is described in three simple steps by using the **Oriented Start-up routine** and the **Basic Application group**.

Steps:

1. Set the password for parameter modification.
2. Execute the **Oriented Start-up routine**.
3. Set the parameters of the **Basic Application group**.

5.2.1 Password Setting in P0000

Step	Action/Result	Display Indication
1	- Monitoring mode - Press "Menu" (right soft key)	
2	- Group "00 ALL PARAMETERS" is already selected - Press "Select"	
3	- Parameter "Access to Parameters P0000: 0" is already selected - Press "Select"	
4	- To set the password, press the Up Arrow until number 5 is displayed in the keypad	
5	- When number 5 is displayed in the keypad, press "Save"	
6	- If the setting has been properly performed, the keypad should display "Access to Parameters P0000: 5" - Press "Return" (left soft key)	
7	- Press "Return"	
8	- The display returns to the Monitoring mode	

Figure 5.1 - Steps for allowing parameters modification via P0000

5.2.2 Oriented Start-Up

There is a group of parameters named "Oriented Start-up" that makes the inverter settings easier. Inside this group, there is a parameter P0317, that shall be set to enter into the Oriented Start-up routine.

The Oriented Start-up routine allows you to quickly set up the inverter for operation with the line and motor used. This routine prompts you for the most commonly used parameters in a logic sequence.

In order to enter into the Oriented Start-up routine, follow the sequence presented in [Figure 5.2 on page 5-4](#), first modifying parameter P0317 = 1 and then, setting the other parameters as they are displayed on the HMI.

Setting the parameters in the Oriented Start-Up routine causes the automatic content modification of the other parameters and/or internal inverter variables.

During the Oriented Start-up routine, the message "Config" will be displayed at the left top corner of the HMI display.

Step	Action/Result	Display Indication	Step	Action/Result	Display Indication
1	- Monitoring mode - Press "Menu" (right soft key)		2	- Group "00 ALL PARAMETERS" has been already selected 	
3	- Group "01 PARAMETER GROUPS" is selected 		4	- Group "02 ORIENTED START-UP" is then selected - Press "Select"	
5	- Parameter "Oriented Start- Up P0317: No" has been already selected - Press "Select"		6	- The value of "P0317 = [000] No" is displayed 	
7	- The parameter value is modified to "P0317 = [001] Yes" - Press "Save"		8	- At this point the Oriented Start-up routine starts and the "Config" status is displayed at the top left corner of the keypad - The parameter "Language P0201: English" is already selected - If needed, change the language by pressing "Select". Then, press or to scroll through the available options and press "Save" to select a different language 	

First Time Power-Up and Start-Up

Step	Action/Result	Display Indication	Step	Action/Result	Display Indication
9	<p>- If needed, change the value of P0202 according to the type of control. To do so, press "Select"</p> <p>- The settings listed here are valid only for P0202 = 0 (V/f 60 Hz) or P0202 = 1 (V/f 50 Hz). For other options (Adjustable V/f, VVW, or Vector modes), please refer to the programming manual</p> 		10	<p>- If needed, change the value of P0296 according to the line rated voltage. To do so, press "Select". This modification will affect P0151, P0153, P0185, P0321, P0322, P0323, and P0400</p> 	
11	<p>- If needed, change the value of P0298 according to the inverter application. To do so, press "Select"</p> <p>This modification will affect P0156, P0157, P0158, P0401, P0404 and P0410 (this last one only if P0202 = 0, 1, or 2 - V/f control)</p> <p>The time and the activation level of the overload protection will be affected as well</p> 		12	<p>- If needed, change the value of P0398 according to the motor service factor. To do so, press "Select". This modification will affect the current value and the activation time of the motor overload function</p> 	
13	<p>- If needed, change the value of P0400 according to the motor rated voltage. To do so, press "Select". This modification adjusts the output voltage by a factor $x = P0400/P0296$</p> 		14	<p>- If needed, change the value of P0401 according to the motor rated current. To do so, press "Select". This modification will affect P0156, P0157, P0158, and P0410</p> 	
15	<p>- If needed, set P0402 according to the motor rated speed. To do so, press "Select". This modification affects P0122 to P0131, P0133, P0134, P0135, P0182, P0208, P0288, and P0289</p> 		16	<p>- If needed, set P0403 according to the motor rated frequency. To do so, press "Select". This modification affects P0402</p> 	
17	<p>- If needed, change the value of P0404 according to the motor rated power. To do so, press "Select"</p> <p>This modification affects P0410</p> 		18	<p>- This parameter will only be visible if the encoder board ENC1 is installed in the inverter</p> <p>- If there is an encoder connected to the motor, set P0405 according to the encoder pulses number. To do so, press "Select"</p> 	
19	<p>- If needed, set P0406 according to the motor ventilation. To do so, press "Select"</p> <p>- To complete the Oriented Start-Up routine, press "Reset" (left soft key) or .</p>		20	<p>- After few seconds, the display returns to the Monitoring mode</p>	

Figure 5.2 - Oriented Start-up

5.2.3 Setting Basic Application Parameters

After running the Oriented Start-up routine and properly setting the parameters, the inverter is ready to operate in the V/f mode.

The inverter has a number of other parameters that allow its adaptation to the most different applications. This manual presents some basic parameters, whose setting is necessary in the majority of cases. To make this task easier, there is a group named Basic Application. A summary of the parameters inside this group is listed in Table 5.1 on page 5-6. There is also a group of read only parameters that shows the value of the most important inverter variables such as voltage, current, etc. The main parameters comprised in this group are listed in Table 5.2 on page 5-7. For further details, please refer to the CFW-11 programming manual.

Follow steps outlined in Figure 5.3 on page 5-5 to set the parameters of the Basic Application group.

The procedure for start-up in the V/f operation mode is finished after setting these parameters.

Step	Action/Result	Display Indication	Step	Action/Result	Display Indication
1	- Monitoring mode - Press "Menu" (right soft key)		2	- Group "00 ALL PARAMETERS" has been already selected	
3	- Group "01 PARAMETER GROUPS" is then selected		4	- Group "02 ORIENTED START-UP" is then selected	
5	- Group "03 CHANGED PARAMETERS" is selected		6	- Group "04 BASIC APPLICATION" is selected - Press "Select"	
7	- Parameter "Acceleration Time P0100: 20.0 s" has been already selected - If needed, set P0100 according to the desired acceleration time. To do so, press "Select" - Proceed similarly until all parameters of group "04 BASIC APPLICATION" have been set. When finished, press "Return" (left soft key)		8	- Press "Return"	
9	- The display returns to the Monitoring mode and the inverter is ready to run				

Figure 5.3 - Setting parameters of the Basic Application group

Table 5.1 - Parameters contained in the basic application group

Parameter	Name	Description	Setting Range	Factory Setting	User Setting
P0100	Acceleration Time	- Defines the time to linearly accelerate from 0 up to the maximum speed (P0134) - If set to 0.0 s, it means no acceleration ramp	0.0 to 999.0 s	20.0 s	
P0101	Deceleration Time	- Defines the time to linearly decelerate from the maximum speed (P0134) up to 0 - If set to 0.0 s, it means no deceleration ramp	0.0 to 999.0 s	20.0 s	
P0133	Minimum Speed	- Defines the minimum and maximum values of the speed reference when the drive is enabled - These values are valid for any reference source	0 to 18000 rpm	90 rpm (60 Hz motor) 75 rpm (50 Hz motor)	
P0134	Maximum Speed			1800 rpm (60 Hz motor) 1500 rpm (50 Hz motor)	
P0135	Max. Output Current (V/F control mode current limitation)	- Avoids motor stall under torque overload condition during the acceleration or deceleration - The factory default setting is for "Ramp Hold": if the motor current exceeds the value set at P0135 during the acceleration or deceleration, the motor speed will not be increased (acceleration) or decreased (deceleration) anymore. When the motor current reaches a value below the programmed in P0135, the motor speed is again increased or decreased - Other options for the current limitation are available. Refer to the CFW-11 programming manual	$0.2 \times I_{rat-HD}$ to $2 \times I_{rat-HD}$	$1.5 \times I_{rat-HD}$	
P0136	Manual Torque Boost	- Operates in low speeds, modifying the output voltage x frequency curve to keep the torque constant - Compensates the voltage drop at the motor stator resistance. This function operates in low speeds increasing the inverter output voltage to keep the torque constant in the V/f mode - The optimal setting is the smallest value of P0136 that allows the motor to start satisfactorily. An excessive value will considerably increase the motor current in low speeds, and may result in a fault (F048, F051, F071, F072, F078 or F183) or alarm (A046, A047, A050 or A110) condition	0 to 9	1	

5

Table 5.2 - Main read only parameters

Parameter	Description	Setting Range	Parameter	Description	Setting Range
P0001	Speed Reference	0 to 18000 rpm	P0045	Fan Enabled Time	0 to 65535h
P0002	Motor Speed	0 to 18000 rpm	P0048	Present Alarm	0 to 999
P0003	Motor Current	0.0 to 4500.0 A	P0049	Present Fault	0 to 999
P0004	DC Link Voltage (Ud)	0 to 2000 V	P0050	Last Fault	0 to 999
P0005	Motor Frequency	0.0 to 300.0 Hz	P0051	Last Fault Day/Month	00/00 to 31/12
P0006	VFD Status	0 = Ready 1 = Run 2 = Undervoltage 3 = Fault 4 = Self-tuning 5 = Configuration 6 = DC-Braking 7 = STO	P0052	Last Fault Year	00 to 99
P0007	Motor Voltage	0 to 2000 V	P0053	Last Fault Time	00:00 to 23:59
P0009	Motor Torque	-1000.0 to 1000.0 %	P0054	Second Fault	0 to 999
P0010	Output Power	0.0 to 6553.5 kW	P0055	Second Flt. Day/Month	00/00 to 31/12
P0012	DI8 to DI1 Status	0000h to 00FFh	P0056	Second Fault Year	00 to 99
P0013	DO5 to DO1 Status	0000h to 001Fh	P0057	Second Fault Time	00:00 to 23:59
P0018	AI1 Value	-100.00 to 100.00 %	P0058	Third Fault	0 to 999
P0019	AI2 Value	-100.00 to 100.00 %	P0059	Third Fault Day/Month	00/00 to 31/12
P0020	AI3 Value	-100.00 to 100.00 %	P0060	Third Fault Year	00 to 99
P0021	AI4 Value	-100.00 to 100.00 %	P0061	Third Fault Time	00:00 to 23:59
P0023	Software Version	0.00 to 655.35	P0062	Fourth Fault	0 to 999
P0027	Accessories Config. 1	Hexadecimal code representing the identified accessories. Refer to Chapter 7 OPTION KITS AND ACCESSORIES on page 7-1	P0063	Fourth Flt. Day/Month	00/00 to 31/12
P0028	Accessories Config. 2		P0064	Fourth Fault Year	00 to 99
P0029	Power Hardware Config.	Hexadecimal code according to the available models and option kits. Refer to the software manual for a complete code list	P0065	Fourth Fault Time	00:00 to 23:59
P0030	IGBTs Temperature U	-20.0 to 150.0 °C (-4 °F to 302 °F)	P0066	Fifth Fault	0 to 999
P0031	IGBTs Temperature V	-20.0 to 150.0 °C (-4 °F to 302 °F)	P0067	Fifth Fault Day/Month	00/00 to 31/12
P0032	IGBTs Temperature W	-20.0 to 150.0 °C (-4 °F to 302 °F)	P0068	Fifth Fault Year	00 to 99
P0033	Rectifier Temperature	-20.0 to 150.0 °C (-4 °F to 302 °F)	P0069	Fifth Fault Time	00:00 to 23:59
P0034	Internal Air Temp.	-20.0 to 150.0 °C (-4 °F to 302 °F)	P0070	Sixth Fault	0 to 999
P0036	Fan Heatsink Speed	0 to 15000 rpm	P0071	Sixth Fault Day/Month	00/00 to 31/12
P0037	Motor Overload Status	0 to 100 %	P0072	Sixth Fault Year	00 to 99
P0038	Encoder Speed	0 to 65535 rpm	P0073	Sixth Fault Time	00:00 to 23:59
P0040	PID Process Variable	0.0 to 100.0 %	P0074	Seventh Fault	0 to 999
P0041	PID Setpoint Value	0.0 to 100.0 %	P0075	Seventh Flt.Day/Month	00/00 to 31/12
P0042	Time Powered	0 to 65535h	P0076	Seventh Fault Year	00 to 99
P0043	Time Enabled	0.0 to 6553.5h	P0077	Seventh Fault Time	00:00 to 23:59
P0044	kWh Output Energy	0 to 65535 kWh	P0078	Eighth Fault	0 to 999
			P0079	Eighth Flt. Day/Month	00/00 to 31/12
			P0080	Eighth Fault Year	00 to 99
			P0081	Eighth Fault Time	00:00 to 23:59
			P0082	Ninth Fault	0 to 999
			P0083	Ninth Fault Day/Month	00/00 to 31/12
			P0084	Ninth Fault Year	00 to 99
			P0085	Ninth Fault Time	00:00 to 23:59
			P0086	Tenth Fault	0 to 999
			P0087	Tenth Fault Day/Month	00/00 to 31/12
			P0088	Tenth Fault Year	00 to 99
			P0089	Tenth Fault Time	00:00 to 23:59
			P0090	Current At Last Fault	0.0 to 4000.0 A
			P0091	DC Link At Last Fault	0 to 2000 V
			P0092	Speed At Last Fault	0 to 18000 rpm
			P0093	Reference Last Fault	0 to 18000 rpm
			P0094	Frequency Last Fault	0.0 to 300.0 Hz
			P0095	Motor Volt.Last Fault	0 to 2000 V
			P0096	Dlx Status Last Fault	0000h to 00FFh
			P0097	DOx Status Last Fault	0000h to 001Fh

5.3 SETTING DATE AND TIME





Step	Action/Result	Display Indication
1	Monitoring mode - Press "Menu" (right soft key)	Ready C LOC 0rpm 0 rpm 0.0 A 0.0 Hz 16:10 Menu
2	- Group "00 ALL PARAMETERS" is already selected 	Ready C LOC 0rpm 00 ALL PARAMETERS 01 PARAMETER GROUPS 02 ORIENTED START-UP 03 CHANGED PARAMETERS Return 16:10 Select
3	- Group "01 PARAMETER GROUPS" is selected - Press "Select"	Ready C LOC 0rpm 00 ALL PARAMETERS 01 PARAMETER GROUPS 02 ORIENTED START-UP 03 CHANGED PARAMETERS Return 16:10 Select
4	- A new list of groups is displayed and group "20 Ramps" is selected - Press  until you reach group "30 HMI"	Ready C LOC 0rpm 20 Ramps 21 Speed References 22 Speed Limits 23 V/F Control Return 16:10 Select
5	- Group "30 HMI" is selected - Press "Select"	Ready C LOC 0rpm 27 V/F DC Volt. Limit. 28 Dynamic Braking 29 Vector Control 30 HMI Return 16:10 Select
6	- Parameter "Day P0194" is already selected - If needed, set P0194 according to the actual day. To do so, press "Select" and then,  or  to change P0194 value - Follow the same steps to set parameters "Month P0195" to "Seconds P0199"	Ready C LOC 0rpm Day P0194: 06 Month P0195: 10 Return 16:10 Select
7	- Once the setting of P0199 is over, the Real Time Clock is now updated - Press "Return" (left soft key)	Ready C LOC 0rpm Minutes P0198: 11 Seconds P0199: 34 Return 18:11 Select
8	- Press "Return"	Ready C LOC 0rpm 27 V/F DC Volt. Limit. 28 Dynamic Braking 29 Vector Control 30 HMI Return 18:11 Select
9	- Press "Return"	Ready C LOC 0rpm 00 ALL PARAMETERS 01 PARAMETER GROUPS 02 ORIENTED START-UP 03 CHANGED PARAMETERS Return 18:11 Select
10	- The display is back to the Monitoring mode	Ready C LOC 0rpm 0 rpm 0.0 A 0.0 Hz 18:11 Menu

Figure 5.4 - Setting date and time

5.4 BLOCKING PARAMETERS MODIFICATION

To prevent unauthorized or unintended parameters modification, parameter P0000 should be set to a value different from 5. Follow the same procedures described in [Item 5.2.1 Password Setting in P0000 on page 5-2](#).

5.5 HOW TO CONNECT A PC



NOTE!

- Always use a standard host/device shielded USB cable. Unshielded cables may lead to communication errors.
- Recommended cables: Samtec:
 - USBC-AM-MB-B-B-S-1 (1 meter).
 - USBC-AM-MB-B-B-S-2 (2 meters).
 - USBC-AM-MB-B-B-S-3 (3 meters).
- The USB connection is galvanically isolated from the mains power supply and from other high voltages internal to the inverter. However, the USB connection is not isolated from the Protective Ground (PE). Use an isolated notebook for the USB connection or a desktop connected to the same Protective Ground (PE) of the inverter.

Install the SuperDrive G2 software to control motor speed, view, or edit inverter parameters through a personal computer (PC).

Basic procedures for transferring data from the PC to the inverter:

1. Install the SuperDrive G2 software in the PC.
2. Connect the PC to the inverter through a USB cable.
3. Start SuperDrive G2.
4. Choose "Open" and the files stored in the PC will be displayed.
5. Select the file.
6. Use the command "Write Parameters to the Drive".
 - All parameters are now transferred to the inverter.

Refer to the CFW-11 programming manual and to SoftPLC manual for further details.

5.6 FLASH MEMORY MODULE

Location as presented in [Figure 2.2 on page 2-6](#) item D.

Functions:

- Store a copy of the inverter parameters.
- Transfer parameters stored in the FLASH memory to the inverter.
- Transfer firmware stored in the FLASH memory to the inverter.
- Store programs created by the SoftPLC.

Whenever the inverter is powered up, this program is transferred to the RAM memory located in the inverter control board and executed.

Refer to the CFW-11 programming manual and to SoftPLC manual for further details.



ATTENTION!

Before installing or removing the FLASH memory module, disconnect the inverter power supply and wait for the complete discharge of the capacitors.

6 TROUBLESHOOTING AND MAINTENANCE

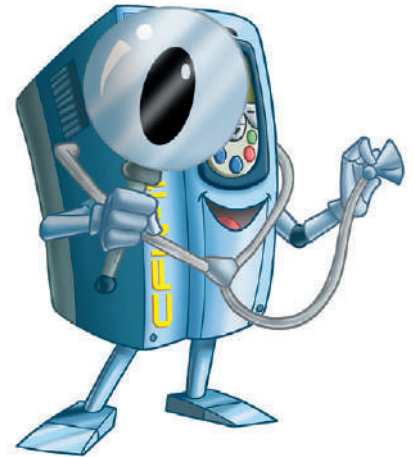

This chapter presents:

- Lists all faults and alarms that may occur.
- Indicates the possible causes of each fault and alarm.
- Lists most frequent problems and corrective actions.
- Instructions for periodic inspections and preventive maintenance on the equipment.

6.1 OPERATION OF THE FAULTS AND ALARMS

When a fault is detected (fault (FXXX)):

- The PWM pulses are blocked.
- The keypad displays the fault code and description.
- The "STATUS" LED starts flashing red.
- The output relay set to "NO FAULT" opens.
- Some data is saved in the control circuit EEPROM memory:
 - Keypad and EP (Electronic Pot) speed references, in case the function "Reference backup" is enabled in P0120.
 - The fault code that occurred (shifts the last nine previous faults and alarms).
 - The state of the motor overload function integrator.
 - The state of the operating hours counter (P0043) and the powered-up hours counter (P0042).

Reset the inverter to return the drive to a "READY" condition in the event of a fault. The following reset options are available:

- Removing the power supply and reapplying it (power-on reset).
- Pressing the operator key  (manual reset).
- Through the "Reset" soft key.
- Automatically by setting P0340 (auto-reset).
- Through a digital input: DIx = 20 (P0263 to P0270).

When an alarm situation (alarm (AXXX)) is detected:

- ☑ The keypad displays the alarm code and description.
- ☑ The "STATUS" LED changes to yellow.
- ☑ The PWM pulses are not blocked (the inverter is still operating).

6.2 FAULTS, ALARMS AND POSSIBLE CAUSES

Table 6.1 - Faults, alarms and possible causes

Fault/Alarm	Description	Possible Causes
F006 Imbalance or Input Phase Loss	Mains voltage imbalance too high or phase missing in the input power supply. Note: - If the motor is unloaded or operating with reduced load this fault may not occur. - Fault delay is set at parameter P0357 P0357 = 0 disables the fault. - In the case of using single-phase it is necessary to disable this failure.	<ul style="list-style-type: none"> ☑ Phase missing at the inverter's input power supply. ☑ Input voltage imbalance > 5 %. ☑ Phase loss at L3/R or L3/S may cause F021 or F185. ☑ Phase loss at L3/T will cause F006.
F021 DC Link Undervoltage	DC Link undervoltage condition occurred.	<ul style="list-style-type: none"> ☑ The input voltage is too low and the DC Link voltage dropped below the minimum permitted value (monitor the value at Parameter P0004): Ud < 223 V - For a 220 / 230 V three-phase input voltage. Ud < 385 V - For a 380 V input voltage (P0296 = 1). Ud < 405 V - For a 400 / 415 V input voltage (P0296 = 2). Ud < 446 V - For a 440 / 460 V input voltage (P0296 = 3). Ud < 487 V - For a 480 V input voltage (P0296 = 4). ☑ Phase loss in the input power supply. ☑ Pre-charge circuit failure. ☑ Parameter P0296 was set to a value above of the power supply rated voltage.
F022 DC Link Overvoltage	DC Link overvoltage condition occurred.	<ul style="list-style-type: none"> ☑ The input voltage is too high and the DC Link voltage surpassed the maximum permitted value: Ud > 400 V - For 220 / 230 V input models (P0296 = 0) Ud > 800 V - For 380 / 480 V input models (P0296 = 1, 2, 3, or 4). ☑ Inertia of the driven-load is too high or deceleration time is too short. ☑ Parameters P0151 or P0153 or P0185 set to high.
F030 Power Module U Fault	Power Module U IGBTs desaturation.	☑ Short-circuit between motor phases U and V or U and W.
F034 Power Module V Fault	Power Module V IGBTs desaturation.	☑ Short-circuit between motor phases V and U or V and W.
F038 Power Module W Fault	Power Module W IGBTs desaturation.	☑ Short-circuit between motor phases W and U or W and V.
F042 DB IGBT Fault	Desaturation of Dynamic Braking IGBT occurred.	☑ Short-circuit between the connection cables of the dynamic braking resistor.
A046 High Load on Motor	Load is too high for the used motor. Note: It may be disabled by setting P0348 = 0 or 2.	<ul style="list-style-type: none"> ☑ Settings of P0156, P0157, and P0158 are too low for the used motor. ☑ Motor shaft load is excessive.
A047 IGBT Overload Alarm	An IGBT overload alarm occurred. Note: It may be disabled by setting P0350 = 0 or 2.	☑ High current at the inverter output - consider the values of the Table 8.1 on page 8-2 to Table 8.5 on page 8-4 according to the used switching frequency.
F048 IGBT Overload Fault	An IGBT overload fault occurred.	☑ High current at the inverter output – consider the values of the Table 8.1 on page 8-2 to Table 8.5 on page 8-4 according to the used switching frequency.
A050 IGBT High Temperature	A high temperature alarm was detected by the NTC temperature sensors located on the IGBTs. Note: It may be disabled by setting P0353 = 2 or 3.	<ul style="list-style-type: none"> ☑ Surrounding air temperature is too high (> 45 °C (113 °F)) and output current is too high. ☑ Heatsink fan blocked or defective. ☑ Very dirty heatsink.
F051 IGBT Overtemperature	A high temperature fault was detected by the NTC temperature sensors located on the IGBTs.	

Fault/Alarm	Description	Possible Causes
F065 Encoder Signal Fault (SW)	Feedback obtained via encoder does not match the commanded speed. The fault can be disabled via parameter P0358.	<input checked="" type="checkbox"/> Wiring between encoder and encoder interface accessory interrupted. <input checked="" type="checkbox"/> Encoder is defective. <input checked="" type="checkbox"/> Encoder coupling to the motor is broken. <input checked="" type="checkbox"/> Inverter operating in current limit (In case the application needs to run in such condition, this fault should be disabled via parameter P0358).
F066 Encoder Signal Fault (SW)	Feedback obtained via encoder does not match the commanded speed. The fault can be disabled via parameter P0358.	<input checked="" type="checkbox"/> Wiring between encoder and encoder interface accessory interrupted. <input checked="" type="checkbox"/> Encoder is defective. <input checked="" type="checkbox"/> Encoder coupling to the motor is broken. <input checked="" type="checkbox"/> Inverter operating in current limit (in case the application needs to run in such condition, this fault should be disabled via parameter P0358).
F067 Incorrect Encoder/ Motor Wiring	Fault related to the phase relation of the encoder signals, if P0202 = 4 and P0408 = 0, 2, 3 or 4. Note: - It is not possible to reset this fault (when P0408 > 1). - In this case, turn off the power supply, solve the problem, and then turn it on again. - When P0408 = 0, it is possible to reset this fault. This fault could be disabled by means of parameter P0358. In this case it is possible to reset this fault.	<input checked="" type="checkbox"/> Output motor cables U, V, W are inverted. <input checked="" type="checkbox"/> Encoder channels A and B are inverted. <input checked="" type="checkbox"/> Encoder was not properly mounted. <input checked="" type="checkbox"/> Motor with locked rotor or dragging at the start.
F071 Output Overcurrent	Output overcurrent fault.	<input checked="" type="checkbox"/> Excessive load inertia or acceleration time too short. <input checked="" type="checkbox"/> Settings of P0135 or P0169 and P0170 are too high.
F072 Motor Overload	The motor overload protection operated. Note: It may be disabled by setting P0348 = 0 or 3.	<input checked="" type="checkbox"/> Settings of P0156, P0157, and P0158 are too low for the used motor. <input checked="" type="checkbox"/> Motor shaft load is excessive.
F074 Ground Fault	A ground fault occurred either in the cable between the inverter and the motor or in the motor itself. Note: It may be disabled by setting P0343 = 0.	<input checked="" type="checkbox"/> Shorted wiring in one or more of the output phases. <input checked="" type="checkbox"/> Motor cable capacitance is too large, resulting in current peaks at the output. ⁽¹⁾
F076 Motor Current Imbalance	Fault of motor current imbalance. Note: It may be disabled by setting P0342 = 0.	<input checked="" type="checkbox"/> Loose connection or broken wiring between the motor and inverter connection. <input checked="" type="checkbox"/> Vector control with wrong orientation. <input checked="" type="checkbox"/> Vector control with encoder, encoder wiring or encoder motor connection inverted.
F077 DB Resistor Overload	The dynamic braking resistor overload protection operated.	<input checked="" type="checkbox"/> Excessive load inertia or deceleration time too short. <input checked="" type="checkbox"/> Motor shaft load is excessive. <input checked="" type="checkbox"/> Parameter P0154 and P0155 incorrect setting.
F078 Motor Overtemperature	Fault related to the PTC temperature sensor installed in the motor. Note: - It may be disabled by setting P0351 = 0 or 3. - It is necessary to set an analog input/output to the PTC function.	<input checked="" type="checkbox"/> Excessive load at the motor shaft. <input checked="" type="checkbox"/> Excessive duty cycle (too many starts/stops per minute). <input checked="" type="checkbox"/> Surrounding air temperature too high. <input checked="" type="checkbox"/> Loose connection or short-circuit (resistance < 100 Ω) in the wiring connected to the motor thermistor. <input checked="" type="checkbox"/> Motor thermistor is not installed. <input checked="" type="checkbox"/> Blocked motor shaft.
F079 Encoder Signal Fault	Lack of encoder signals. The fault can be disabled via switches of the ENC1, ENC2 board.	<input checked="" type="checkbox"/> Broken wiring between motor encoder and option kit for encoder interface. <input checked="" type="checkbox"/> Defective encoder. <input checked="" type="checkbox"/> Encoder accessory defective or not well installed on the product, and control configured for vector with encoder.
F080 CPU Watchdog	Microcontroller watchdog fault.	<input checked="" type="checkbox"/> Electrical noise.
F082 Copy Function Fault	Fault while copying parameters.	<input checked="" type="checkbox"/> Communication problem with the HMI.
F084 Auto-diagnosis Fault	Auto-diagnosis fault.	<input checked="" type="checkbox"/> Please contact WEG.
A088 Communication Lost	Indicates a problem between the keypad and control board communication.	<input checked="" type="checkbox"/> Loose keypad cable connection. <input checked="" type="checkbox"/> Electrical noise in the installation.
A090 External Alarm	External alarm via digital input. Note: It is required to set a digital input to "No external alarm".	<input checked="" type="checkbox"/> Wiring was not connected to the digital input (DI1 to DI8) set to "No external alarm".
F091 External Fault	External fault via digital input. Note: It is required to set a digital input to "No external fault".	<input checked="" type="checkbox"/> Wiring was not connected to the digital input (DI1 to DI8) set to "No external fault".

Fault/Alarm	Description	Possible Causes
F099 Invalid Current Offset	Current measurement circuit is measuring a wrong value for null current.	<ul style="list-style-type: none"> <input checked="" type="checkbox"/> Defect in the inverter internal circuitry.
A110 High Motor Temperature	Alarm related to the PTC temperature sensor installed in the motor. Note: - It may be disabled by setting P0351 = 0 or 2. - It is required to set the analog input/output to the PTC function.	<ul style="list-style-type: none"> <input checked="" type="checkbox"/> Excessive load at the motor shaft. <input checked="" type="checkbox"/> Excessive duty cycle (too many starts/stops per minute). <input checked="" type="checkbox"/> Surrounding air temperature too high. <input checked="" type="checkbox"/> Loose connection or short-circuit (resistance < 100 Ω) in the wiring connected to the motor termistor. <input checked="" type="checkbox"/> Motor termistor is not installed. <input checked="" type="checkbox"/> Blocked motor shaft.
A128 Timeout for Serial Communication	Indicates that the inverter stopped receiving valid messages within a certain time interval. Note: It may be disabled by setting P0314 = 0.0 s.	<ul style="list-style-type: none"> <input checked="" type="checkbox"/> Check the wiring and grounding installation. <input checked="" type="checkbox"/> Make sure the inverter has sent a new message within the time interval set at P0314.
A129 Anybus is Offline	Alarm that indicates interruption of the Anybus-CC communication.	<ul style="list-style-type: none"> <input checked="" type="checkbox"/> PLC entered into the idle state. <input checked="" type="checkbox"/> Programming error. Master and slave set with a different number of I/O words. <input checked="" type="checkbox"/> Communication with master has been lost (broken cable, unplugged connector, etc.).
A130 Anybus Access Error	Alarm that indicates an access error to the Anybus-CC communication module.	<ul style="list-style-type: none"> <input checked="" type="checkbox"/> Defective, unrecognized, or improperly installed Anybus-CC module. <input checked="" type="checkbox"/> Conflict with a WEG option board.
A133 CAN Not Powered	Alarm indicating that the power supply was not connected to the CAN controller.	<ul style="list-style-type: none"> <input checked="" type="checkbox"/> Broken or loose cable. <input checked="" type="checkbox"/> Power supply is off.
A134 Bus Off	Inverter CAN interface has entered into the bus-off state.	<ul style="list-style-type: none"> <input checked="" type="checkbox"/> Incorrect communication baud-rate. <input checked="" type="checkbox"/> Two nodes configured with the same address in the network. <input checked="" type="checkbox"/> Wrong cable connection (inverted signals).
A135 CANopen Communication Error	Alarm that indicates a communication error.	<ul style="list-style-type: none"> <input checked="" type="checkbox"/> Communication problems. <input checked="" type="checkbox"/> Wrong master configuration/settings. <input checked="" type="checkbox"/> Incorrect configuration of the communication objects.
A136 Idle Master	Network master has entered into the idle state.	<ul style="list-style-type: none"> <input checked="" type="checkbox"/> PLC in IDLE mode. <input checked="" type="checkbox"/> Bit of the PLC command register set to zero (0).
A137 DNet Connection Timeout	I/O connection timeout - DeviceNet communication alarm.	<ul style="list-style-type: none"> <input checked="" type="checkbox"/> One or more allocated I/O connections have entered into the timeout state.
A138 ⁽²⁾ Profibus DP Interface in Clear Mode	It indicates that the inverter received a command from the Profibus DP network master to enter the clear mode.	<ul style="list-style-type: none"> <input checked="" type="checkbox"/> Verify the network master status, making sure it is in execution mode (Run). <input checked="" type="checkbox"/> Refer to the Profibus DP communication manual for more information.
A139 ⁽²⁾ Offline Profibus DP Interface	It indicates an interruption in the communication between the Profibus DP network master and the inverter.	<ul style="list-style-type: none"> <input checked="" type="checkbox"/> Verify whether the network master is correctly configured and operating normally. <input checked="" type="checkbox"/> Verify the network installation in a general manner - cable routing, grounding. <input checked="" type="checkbox"/> Refer to the Profibus DP communication manual for more information.
A140 ⁽²⁾ Profibus DP Module Access Error	It indicates an error in the access to the Profibus DP communication module data.	<ul style="list-style-type: none"> <input checked="" type="checkbox"/> Verify whether the Profibus DP module is correctly fit into the slot 3. <input checked="" type="checkbox"/> Refer to the Profibus DP communication manual for more information.
F150 Motor Overspeed	Overspeed fault. It is activated when the real speed exceeds the value of P0134 x (100 % + P0132) for more than 20 ms.	<ul style="list-style-type: none"> <input checked="" type="checkbox"/> Wrong settings of P0161 and/or P0162. <input checked="" type="checkbox"/> Problem with the hoist-type load.
F151 FLASH Memory Module Fault	FLASH Memory Module fault (MMF-03).	<ul style="list-style-type: none"> <input checked="" type="checkbox"/> Defective FLASH memory module. <input checked="" type="checkbox"/> FLASH memory module is not connected properly.
A152 Internal Air High Temperature	Alarm indicating that the internal air temperature is too high. Note: It may be disabled by setting P0353 = 1 or 3.	<ul style="list-style-type: none"> <input checked="" type="checkbox"/> Surrounding air temperature too high (> 45 °C (113 °F)) and excessive output current. <input checked="" type="checkbox"/> Defective internal fan. <input checked="" type="checkbox"/> High temperature (> 45 °C (113 °F)) inside the cabinet.
F153 Internal Air Overtemperature	Internal air overtemperature fault.	
F156 Undertemperature	Undertemperature fault, measured at the IGBTs temperature sensors.	<ul style="list-style-type: none"> <input checked="" type="checkbox"/> Surrounding air temperature ≤ -30 °C (-22 °F) .
F160 Safety Stop Relays	Safety Stop relay fault.	<ul style="list-style-type: none"> <input checked="" type="checkbox"/> It was only applied +24 Vdc to one STO input (STO1 or STO2). <input checked="" type="checkbox"/> One of the relays is defective.

Fault/Alarm	Description	Possible Causes
F161 Timeout PLC11CFW-11	<input checked="" type="checkbox"/> Refer to the PLC11-01 Module programming manual.	
A162 Incompatible PLC Firmware		
A163 Break Detect AI1	It indicates that the AI1 current (4-20 mA or 20-4 mA) reference is out of the 4 to 20 mA range.	<input checked="" type="checkbox"/> Broken AI1 cable. <input checked="" type="checkbox"/> Bad contact at the signal connection to the terminal strip.
A164 Break Detect AI2	It indicates that the AI2 current (4-20 mA or 20-4 mA) reference is out of the 4 to 20 mA range.	<input checked="" type="checkbox"/> Broken AI2 cable. <input checked="" type="checkbox"/> Bad contact at the signal connection to the terminal strip.
A165 Break Detect AI3	It indicates that the AI3 current (4-20 mA or 20-4 mA) reference is out of the 4 to 20 mA range.	<input checked="" type="checkbox"/> Broken AI3 cable. <input checked="" type="checkbox"/> Bad contact at the signal connection to the terminal strip.
A166 Break Detect AI4	It indicates that the AI4 current (4-20 mA or 20-4 mA) reference is out of the 4 to 20 mA range.	<input checked="" type="checkbox"/> Broken AI4 cable. <input checked="" type="checkbox"/> Bad contact at the signal connection to the terminal strip.
A177 Fan Replacement	Heatsink fan replacement alarm (P0045 > 50000 hours). Note: This function may be disabled by setting P0354 = 0.	<input checked="" type="checkbox"/> Maximum number of operating hours for the heatsink fan has been reached.
A178 Heatsink Fan Speed Alarm	This alarm indicates a problem with the heatsink fan.	<input checked="" type="checkbox"/> Dirt on the blades and in the bearings of the fan. <input checked="" type="checkbox"/> Defective fan. <input checked="" type="checkbox"/> Defective fan power supply connection.
F179 Heatsink Fan Speed Fault	Heatsink fan speed feedback fault. Note: This function may be disabled by setting P0354 = 0.	<input checked="" type="checkbox"/> Dirt at the heatsink fan blades and ball bearings. <input checked="" type="checkbox"/> Heatsink fan defect. <input checked="" type="checkbox"/> Defective fan power supply connection.
A181 Invalid Clock Value	Invalid clock value alarm.	<input checked="" type="checkbox"/> It is necessary to set date and time at parameters P0194 to P0199. <input checked="" type="checkbox"/> Keypad battery is discharged, defective, or not installed.
F182 Pulse Feedback Fault	Indicates a fault on the output pulses feedback.	<input checked="" type="checkbox"/> No motor connected or the motor connected to the inverter output is too small. <input checked="" type="checkbox"/> Possible defect on the internal circuits of the inverter. Possible solutions: <input checked="" type="checkbox"/> Reset inverter and try again. <input checked="" type="checkbox"/> Set P0356 = 0 and try again
F183 IGBT overload + Temperature	Overtemperature related to the IGBTs overload protection.	<input checked="" type="checkbox"/> Surrounding air temperature too high. <input checked="" type="checkbox"/> Operation with overload at frequencies below 10 Hz – consider the Table 8.1 on page 8-2 and Table 8.5 on page 8-4 values according to the used switching frequency.
F185 Pre-charge Contactor Fault	Fault in the pre-charge contactor circuit.	<input checked="" type="checkbox"/> Open command fuse. Refer to Item 3.2.3.2.2 Command Fuses of Pre-Charge Circuit on page 3-19 . <input checked="" type="checkbox"/> Phase loss at the input in L1/R or L2/S. <input checked="" type="checkbox"/> Defect in the pre-charge contactor and/or related circuit. <input checked="" type="checkbox"/> Inverter CFW11 frame size E powered by DC Link: P0355 should be programd to 0.
F186⁽³⁾ Sensor 1 Temperature Fault	It indicates a temperature fault at the sensor 1.	<input checked="" type="checkbox"/> Motor high temperature.
F187⁽³⁾ Sensor 2 Temperature Fault	It indicates a temperature fault at the sensor 2.	
F188⁽³⁾ Sensor 3 Temperature Fault	It indicates a temperature fault at the sensor 3.	
F189⁽³⁾ Sensor 4 Temperature Fault	It indicates a temperature fault at the sensor 4.	
F190⁽³⁾ Sensor 5 Temperature Fault	It indicates a temperature fault at the sensor 5.	

Fault/Alarm	Description	Possible Causes
A191 ⁽³⁾ Sensor 1 Temperature Alarm	It indicates a temperature alarm at the sensor 1.	<input checked="" type="checkbox"/> Motor high temperature. <input checked="" type="checkbox"/> A problem in the wiring connecting the sensor to the IOE 01 (02 or 03).
A192 ⁽³⁾ Sensor 2 Temperature Alarm	It indicates a temperature alarm at the sensor 2.	
A193 ⁽³⁾ Sensor 3 Temperature Alarm	It indicates a temperature alarm at the sensor 3.	
A194 ⁽³⁾ Sensor 4 Temperature Alarm	It indicates a temperature alarm at the sensor 4.	
A195 ⁽³⁾ Sensor 5 Temperature Alarm	It indicates a temperature alarm at the sensor 5.	
A196 ⁽³⁾ Sensor 1 Cable Alarm	Sensor 1 cable alarm.	<input checked="" type="checkbox"/> Shorted temperature sensor.
A197 ⁽³⁾ Sensor 2 Cable Alarm	Sensor 2 cable alarm.	
A198 ⁽³⁾ Sensor 3 Cable Alarm	Sensor 3 cable alarm.	
A199 ⁽³⁾ Sensor 4 Cable Alarm	Sensor 4 cable alarm.	
A200 ⁽³⁾ Sensor 5 Cable Alarm	Sensor 5 cable alarm.	
F228 Serial Communication Timeout	<input checked="" type="checkbox"/> Refer to the RS-232 / RS-485 Serial communication manual.	
F229 Anybus Offline	<input checked="" type="checkbox"/> Refer to the Anybus-CC communication manual.	
F230 Anybus Access Error		
F233 CAN Bus Power Failure	<input checked="" type="checkbox"/> Refer to the CANopen communication manual and/or the DeviceNet communication manual.	
F234 Bus Off		
F235 CANopen Communication Error	<input checked="" type="checkbox"/> Refer to the CANopen communication manual.	
F236 Master Idle	<input checked="" type="checkbox"/> Refer to the DeviceNet communication manual.	
F237 DeviceNet Connect Timeout		
F238 ⁽²⁾ Profibus DP Interface in Clear Mode	<input checked="" type="checkbox"/> Refer to the Profibus DP communication manual.	
F239 ⁽²⁾ Offline Profibus DP Interface		
F240 ⁽²⁾ Profibus DP Module Access Error		
A700 ⁽⁴⁾ Detached HMI	Alarm or fault related to the HMI disconnection.	<input checked="" type="checkbox"/> RTC function block has been activated in the applicative and the HMI is disconnected from the inverter.
F701 ⁽⁴⁾ Detached HMI		
A702 ⁽⁴⁾ Inverter Disabled	Alarm indicating that the General Enable command is not active.	<input checked="" type="checkbox"/> The SoftPLC Run/Stop command is equal to Run or a movement block has been enable while the inverter is general disabled.

Fault/Alarm	Description	Possible Causes
A704 ⁽⁴⁾ Two Movements Enabled	Two movements have been enabled.	<input checked="" type="checkbox"/> It occurs when two or more movement blocks are enabled simultaneously.
A706 ⁽⁴⁾ Speed Reference Not Programmed for SoftPLC	Speed reference not programmed for SoftPLC .	<input checked="" type="checkbox"/> It occurs when a movement block has been enabled and the speed reference has not been configured for SoftPLC (check P0221 and P0222).

(1) Very long motor cables (longer than 100 meters) present a high parasite capacitance against the ground. The circulation of parasite currents through those capacitances may cause the ground fault circuit activation and thus disabling the inverter with F074, immediately after the inverter enabling. Possible solutions:

- Decrease the carrier frequency (P0297).

- Install an output reactor between the inverter and the motor.

(2) With a Profibus DB module connected into the slot 3 (XC43).

(3) With IOE-01 (02 or 03) modules connected into the slot 1 (XC41).

(4) All the models with a SoftPLC applicative.

6.3 SOLUTIONS FOR THE MOST FREQUENT PROBLEMS

Table 6.2 - Solutions for the most frequent problems

Problem	Point to be Verified	Corrective Action
Motor does not start	Incorrect wiring	1. Check all power and control connections. For instance, the digital inputs set to Start/Stop, General Enable, or no external error shall be connected to the 24 Vdc or to DGND* terminals (refer to Figure 3.19 on page 3-27)
	Analog reference (if used)	1. Check if the external signal is properly connected 2. Check the status of the control potentiometer (if used)
	Incorrect settings	1. Check if parameters are properly set for the application
	Fault	1. Check if the inverter is not blocked due to a fault condition 2. Check if terminals XC1:13 and XC1:11 are not shorted (short-circuit at the 24 Vdc power supply)
	Motor stall	1. Decrease motor overload 2. Increase P0136, P0137 (V/f), or P0169/P0170 (vector control)
Motor speed fluctuates (oscillates)	Loose connection	1. Stop the inverter, turn off the power supply, and tighten all power connections 2. Check all internal connections of the inverter
	Defective reference potentiometer	1. Replace potentiometer
	Oscillation of the external analog reference	1. Identify the cause of the oscillation. If it is caused by electrical noise, use shielded cables or separate from the power and control wiring
	Incorrect settings (vector control)	1. Check parameters P0410, P0412, P0161, P0162, P0175, and P0176 2. Refer to the programming manual
Motor speed too high or too low	Incorrect settings (reference limits)	1. Check if the values of P0133 (minimum speed) and P0134 (maximum speed) are properly set for the motor and application used
	Control signal from the analog reference (if used)	1. Check the level of the reference control signal 2. Check the settings (gain and offset) of parameters P0232 to P0249
	Motor nameplate	1. Check if the motor has been properly sized for the application
Motor does not reach the rated speed, or motor speed starts oscillating around the rated speed (Vector Control)	Settings	1. Decrease P0180 2. Check P0410
Off display	Keypad connections	1. Check the inverter keypad connection
	Power supply voltage	1. Rated values shall be within the limits specified below: 220 / 230 V power supply: - Minimum: 187 V - Maximum: 253 V 380 / 480 V power supply: - Minimum: 323 V - Maximum: 528 V
	Mains supply fuses open	1. Replace fuses
Motor does not operate in the field weakening region (Vector Control)	Settings	1. Decrease P0180
Low motor speed and P0009 = P0169 or P0170 (motor operating with torque limitation), for P0202 = 4 - vector with encoder	Encoder signals are inverted or power connection is inverted	1. Check signals $\bar{A} - A, \bar{B} - B$, refer to the incremental encoder interface manual. If signals are properly installed, exchange two of the output phases. For instance U and V

6.4 INFORMATION FOR CONTACTING TECHNICAL SUPPORT



NOTE!

For technical support and servicing, it is important to have the following information in hand:

- ☑ Inverter model.
- ☑ Serial number, manufacturing date, and hardware revision that are listed in the product nameplate (refer to [Section 2.4 IDENTIFICATION LABELS FOR THE CFW-11](#) on page 2-7).
- ☑ Installed software version (check parameter P0023).
- ☑ Application data and inverter settings.

6.5 PREVENTIVE MAINTENANCE



DANGER!

- ☑ Always turn off the mains power supply before touching any electrical component associated to the inverter.
- ☑ High voltage may still be present even after disconnecting the power supply.
- ☑ To prevent electric shock, wait at least 10 minutes after turning off the input power for the complete discharge of the power capacitors.
- ☑ Always connect the equipment frame to the protective ground (PE). Use the adequate connection terminal in the inverter.



DANGER!

- ☑ Débranchez toujours l'alimentation principale avant d'entrer en contact avec un appareil électrique associé au variateur.
- ☑ Des tensions élevées peuvent encore être présentes, même après déconnexion de l'alimentation.
- ☑ Pour éviter les risques d'électrocution, attendre au moins 10 minutes après avoir coupé l'alimentation d'entrée pour que les condensateurs de puissance soient totalement déchargés.
- ☑ Raccordez toujours la masse de l'appareil à une terre protectrice (PE). Utiliser la borne de connexion adéquate du variateur.



ATTENTION!

The electronic boards have electrostatic discharge sensitive components.

Do not touch the components or connectors directly. If necessary, first touch the grounded metallic frame or wear a ground strap.

**Do not perform any withstand voltage test!
If necessary, consult WEG.**

The inverters require low maintenance when properly installed and operated. The [Table 6.3 on page 6-10](#) presents main procedures and time intervals for preventive maintenance. The [Table 6.4 on page 6-10](#) provides recommended periodic inspections to be performed every 6 months after inverter start-up.

Table 6.3 - Preventive maintenance

Maintenance		Interval	Instructions
Fan replacement		After 50000 operating hours ⁽¹⁾	Replacement procedure shown in Figure 6.1 on page 6-11
Keypad battery replacement		Every 10 years	Refer to the Chapter 4 HMI on page 4-1
Electrolytic capacitors	If the inverter is stocked (not being used): "Reforming"	Every year from the manufacturing date printed in the inverter identification label (refer to Item 2.4 IDENTIFICATION LABELS FOR THE CFW-11 on page 2-7)	Apply power to the inverter (voltage between 220 and 230 Vac, single-phase or three-phase, 50 or 60 Hz) for at least one hour. Then, disconnect the power supply and wait at least 24 hours before using the inverter (reapply power)
	Inverter is being used: replace	Every 10 years	Contact WEG technical support

(1) The inverters are set at the factory for automatic fan control (P0352 = 2), which means that they will be turned on only when the heatsink temperature exceeds a reference value. Therefore, the operating hours of the fan will depend on the inverter usage conditions (motor current, output frequency, cooling air temperature, etc.). The inverter stores the number of operating hours of the fan in parameter P0045. When this parameter reaches 50000 operating hours, the keypad display will show alarm A177.

Table 6.4 - Recommended periodic inspections - Every 6 months

Component	Abnormality	Corrective Action
Terminals, connectors	Loose screws	Tighten
	Loose connectors	
Fans/Cooling system	Dirty fans	Cleaning
	Abnormal acoustic noise	Replace fan. Refer to the Figure 6.1 on page 6-11
	Blocked fan	
	Abnormal vibration	Check the fan connection
	Dust in the cabinet air filter	
Printed circuit boards	Accumulation of dust, oil, humidity, etc.	Cleaning or replacement
	Odor	Cleaning
Power module/ Power connections	Accumulation of dust, oil, humidity, etc.	Replacement
	Loose connection screws	Cleaning
DC Link capacitors	Discoloration/odor/electrolyte leakage	Tighten
	Expanded or broken safety valve	
	Frame expansion	
Power resistors	Discoloration	Replacement
	Odor	
Heatsink	Dust accumulation	Cleaning
	Dirty	

6.5.1 Cleaning Instructions

When it is necessary to clean the inverter, follow the instructions below:

Ventilation system:

- Disconnect the inverter power supply and wait at least 10 minutes.
- Remove the dust from the cooling air inlet by using a soft brush or a flannel.
- Remove the dust from the heatsink fins and from the fan blades by using compressed air.

Electronic boards:

- Disconnect the inverter power supply and wait at least 10 minutes.
- Remove the dust from the electronic board by using an anti-static brush or an ion air gun (Charges Burtes Ion Gun - reference A6030-6DESCO).
- If needed, remove the boards from the inverter.
- Always wear a ground strap.

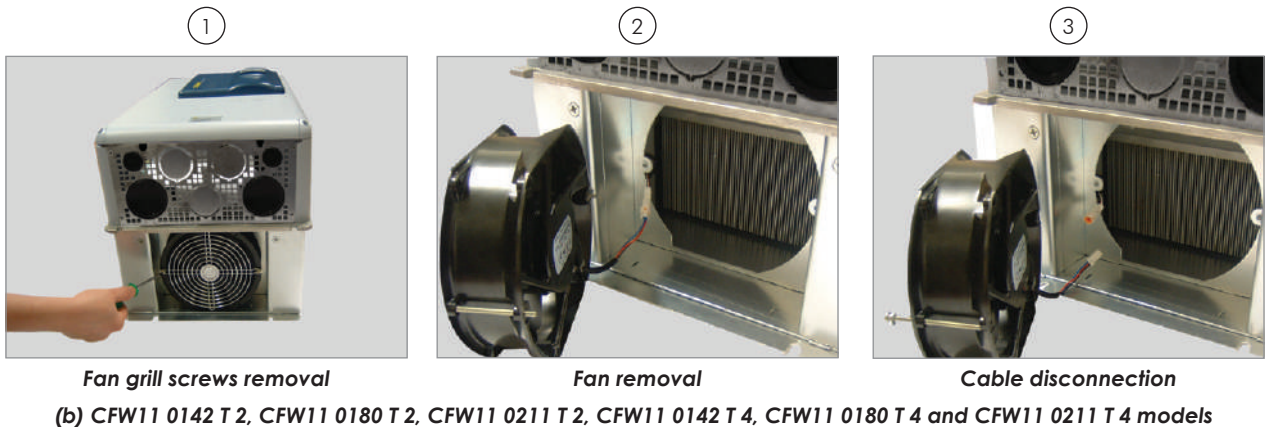
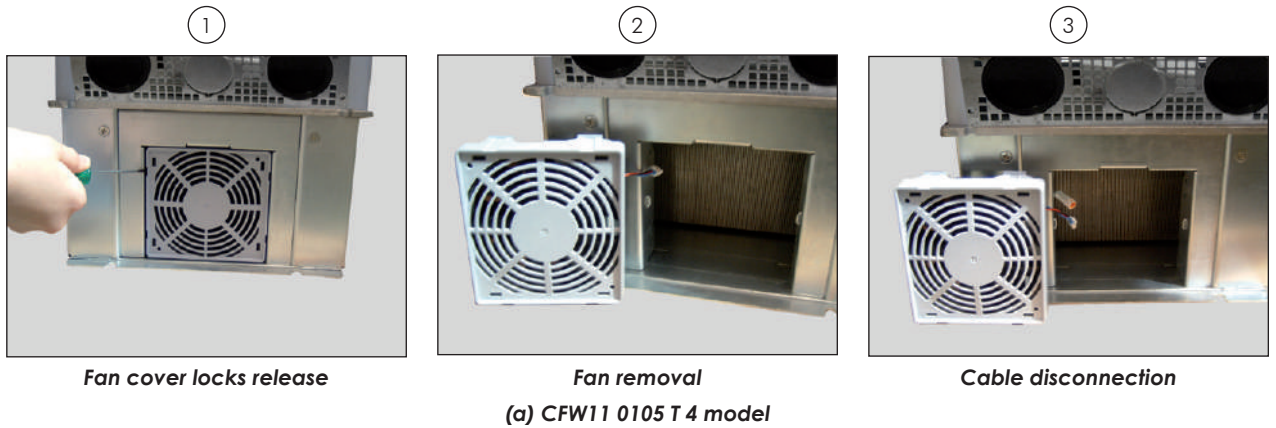

Figure 6.1 - (a) and (b) - Heatsink fan removal

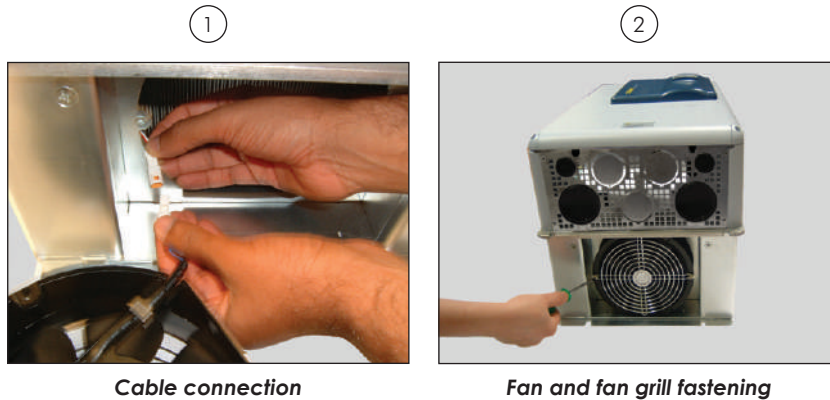
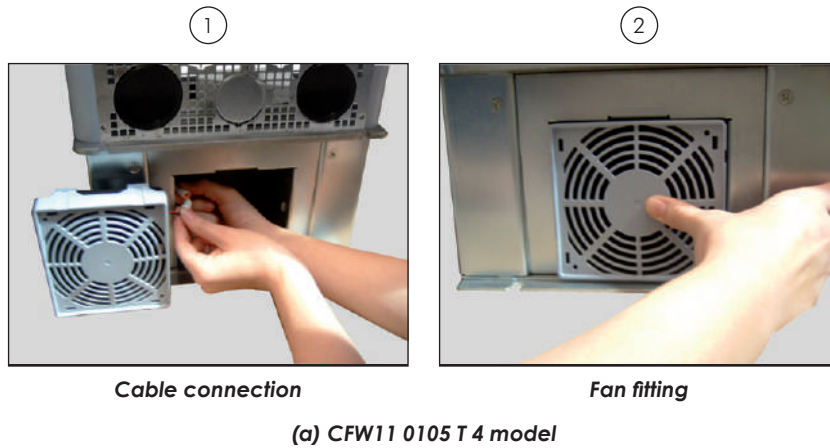

Figure 6.2 - (a) and (b) - Heatsink fan installation

7 OPTION KITS AND ACCESSORIES

This chapter presents:

- ☑ The option kits that can be incorporated to the inverter from the factory:
 - Braking IGBT.
 - Safety Stop according to EN 954-1 category 3.
 - External 24 Vdc power supply for control and keypad.
 - Nema1 protection degree (Frame size E).

- ☑ Instructions for the proper use of the option kits.

- ☑ The accessories that can be integrated to the inverters.



Details for the installation, operation, and programming of the accessories are described in their own manuals and were not included in this chapter.

7.1 OPTION KITS

Some models cannot incorporate all available option kits. Refer to [Table 7.1 on page 7-4](#) for a detailed description of the option kits that are available for each inverter model.

The inverter codification is described in [Chapter 2 GENERAL INSTRUCTIONS on page 2-1](#).

7.1.1 Nema1 Protection Degree

Inverters with the following codification CFW11XXXXXON1. Refer to [Item 3.1.5 Installation of the Inverter with Nema1 Kit \(Option, CFW11....T...ON1...\)](#) on a Wall on page 3-7, and [Section 8.6 NEMA1 KIT on page 8-11](#).

7.1.2 Degree of Protection IP55

Inverters with code CFW11XXXXXO55. Refer to [Item 3.1.6 Access to the Control and Power Terminal Strips on page 3-7](#).

7.1.3 Safety Stop Function

Inverters with the following codification CFW11...O...Y... Refer to [Section 3.3 SAFETY STOP FUNCTION on page 3-34](#).

7.1.4 Braking IGBT

Inverters with the following codification: CFW11XXXXTXODB. Refer to [Item 3.2.3.2 AC Power Supply Considerations on page 3-17](#).

7.1.5 24 Vdc External Control Power Supply

Inverters with the following codification: CFW11...O...W...

The use of this option kit is recommended with communication networks (Profibus, DeviceNet, etc.), since the control circuit and the network communication interface are kept active (with power supply and responding to the network communication commands) even in the event of main power supply interruption.

Inverters with this option have a built-in DC/DC converter with a 24 Vdc input that provides an adequate output for the control circuit. In such manner the power supply of the control circuit will be redundant, i.e., it can be provided by a 24 Vdc external power supply (connection as shown in [Figure 7.1 on page 7-3](#)) or by the standard internal switched-mode power supply of the inverter.

Observe that the inverters with the external 24 Vdc power supply option use terminals XC1:11 and 13 as the input for the external power supply and no longer as an output as in the standard inverter ([Figure 7.1 on page 7-3](#)).

In case of interruption of the external 24 Vdc power source, the digital inputs, outputs and analog outputs will have no power supply, even if the mains power is on. Therefore, it is recommended to keep the 24 Vdc power source always connected to terminals XC1:11 and 13.

The keypad displays warnings indicating the inverter status: if the 24 Vdc power source is connected, if the mains power source is connected, etc.

Connector XC1		
1	+ REF	
2	AI1 +	
3	AI1 -	
4	- REF	
5	AI2 +	
6	AI2 -	
7	AO1	
8	AGND (24 V)	
9	AO2	
10	AGND (24 V)	
11	DGND*	
12	COM	
13	24 Vdc	
14	COM	
15	DI1	
16	DI2	
17	DI3	
18	DI4	
19	DI5	
20	DI6	
21	NC1	DO1 (RL1)
22	C1	
23	NO1	
24	NC2	DO2 (RL2)
25	C2	
26	NO2	
27	NC3	DO3 (RL3)
28	C3	
29	NO3	

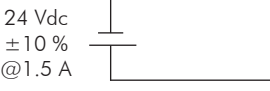

Figure 7.1 - Connection terminals and 24 Vdc external power supply rating



NOTE!

A class 2 power supply must be used in order to comply with the UL508C standard.

7.2 ACCESSORIES

The accessories are installed in the inverter easily and quickly using the "Plug and Play" concept. When the accessory is connected into the slot, the control circuitry identifies the model and displays the installed accessory code in P0027 or P0028. The accessory shall be installed with the inverter power supply off.

The code and model of each available accessory is presented in the [Table 7.1 on page 7-4](#). The accessories can be ordered separately and will be shipped in an individual package containing the components and the manual with detailed instructions for the product installation, operation, and programming.



ATTENTION!

Only one module can be fitted at once in each slot (1, 2, 3, 4, or 5).

Table 7.1 - Accessory models

WEG Part Number	Name	Description	Slot	Identification Parameters	
				P0027	P0028
Control Accessories for Installation in the Slots 1, 2 and 3					
11008162	IOA-01	IOA module: 1 voltage/current analog input (14 bits); 2 digital inputs; 2 voltage/current analog outputs (14 bits); 2 open-collector digital outputs	1	FD--	----
11008099	IOB-01	IOB module: 2 isolated analog inputs (voltage/current); 2 digital inputs; 2 isolated analog outputs (voltage/current) (the programming of the outputs is identical as in the standard CFW-11); 2 open-collector digital outputs	1	FA--	----
11008100	ENC-01	5 to 12 Vdc incremental encoder module, 100 kHz, with an encoder signal repeater	2	--C2	----
11008101	ENC-02	5 to 12 Vdc incremental encoder module, 100 kHz	2	--C2	----
11008102	RS485-01	RS-485 serial communication module (Modbus)	3	----	CE--
11008103	RS232-01	RS-232C serial communication module (Modbus)	3	----	CC--
11008104	RS232-02	RS-232C serial communication module with DIP-switches for programming the microcontroller FLASH memory	3	----	CC--
11008105	CAN/RS485-01	CAN and RS-485 interface module (CANopen/DeviceNet/Modbus)	3	----	CA--
11008106	CAN-01	CAN interface module (CANopen/DeviceNet)	3	----	CD--
11008911	PLC11-01	PLC module	1, 2 and 3	----	--xx ⁽¹⁾⁽³⁾
Anybus-CC Accessories for Installation in the Slot 4					
11008158	DEVICENET-05	DeviceNet interface module	4	----	--xx ⁽²⁾⁽³⁾
10933688	ETHERNET/IP-05	EtherNet/IP interface module	4	----	--xx ⁽²⁾⁽³⁾
11550476	MODBUSTCP-05	Modbus TCP interface module	4	----	--xx ⁽²⁾⁽³⁾
11550548	PROFINETIO-05	PROFINET IO interface module	4	----	--xx ⁽²⁾⁽³⁾
11008107	PROFDP-05	Profibus DP interface module	4	----	--xx ⁽²⁾⁽³⁾
11008161	RS485-05	RS485 (passive) interface module (Modbus)	4	----	--xx ⁽²⁾⁽³⁾
11008160	RS232-05	RS232 (passive) interface module (Modbus)	4	----	--xx ⁽²⁾⁽³⁾
Flash Memory Module for Installation in the Slot 5 – Factory Settings Included ⁽⁶⁾					
11719952	MMF-03	FLASH memory module	5	----	--xx ⁽⁷⁾
Stand-alone HMI, Blank Cover, and Frame for Remote Mounted HMI					
11008913	HMI-01	Stand-alone HMI ⁽⁴⁾	HMI	-	-
11010521	RHMIF-01	Remote HMI frame kit IP65	-	-	-
11010298	HMID-01	Blank cover for the HMI slot	HMI	-	-
10950192	HMI CAB-RS-1M	1 m serial remote keypad cable set	-	-	-
10951226	HMI CAB-RS-2M	2 m serial remote keypad cable set	-	-	-
10951223	HMI CAB-RS-3M	3 m serial remote keypad cable set	-	-	-
10951227	HMI CAB-RS-5M	5 m serial remote keypad cable set	-	-	-
10951240	HMI CAB-RS-7.5M	7.5 m serial remote keypad cable set	-	-	-
10951239	HMI CAB-RS-10M	10 m serial remote keypad cable set	-	-	-
Miscellaneous					
10960842	KN1E-01	Nema1 kit for the frame size E models CFW11 0142 T 2, CFW11 0105 T 4 and CFW11 0142 T 4 (standard for N1 option) ⁽⁵⁾	-	-	-
10960850	KN1E-02	Nema1 kit for the frame size E models CFW11 0180 T 2, CFW11 0211 T 2, CFW11 0180 T 4 and CFW11 0211 T 4 (standard for N1 option) ⁽⁵⁾	-	-	-
10960844	PCSE-01	Kit for power cables shielding - frame E (included in the standard product)	-	-	-
10960847	CCS-01	Kit for control cables shielding (included in the standard product)	-	-	-
10960846	CONRA-01	Control rack (containing the CC11 control board)	-	-	-
11337710	KME-01	Frame size E movement kit	-	-	-

(1) Refer to the PLC module manual.

(2) Refer to the Anybus-CC communication manual.

(3) Refer to the programming manual.

(4) Use DB-9 pin, male-to-female, straight-through cable (serial mouse extension type) for connecting the keypad to the inverter or Null-Modem standard cable. Maximum cable length: 10 m (33 ft).

Examples:

- Mouse extension cable - 1.80 m (6 ft); Manufacturer: Clone.

- Belkin pro series DB9 serial extension cable 5 m (17 ft); Manufacturer: Belkin.

- Cables Unlimited PCM195006 cable, 6 ft DB9 m/f; Manufacturer: Cables Unlimited.

(5) Refer to the [Section 8.6 NEMA1 KIT on page 8-11](#) for more details.

(6) Inverters with serial number below 1011361739 use MMF-01 control card.

(7) The MMF-03 module has a reserved space for the user (for example: write the application software version SoftPLC).

8 TECHNICAL SPECIFICATIONS

This chapter describes the technical specifications (electric and mechanical) of the CFW-11 inverter series frame size E models.

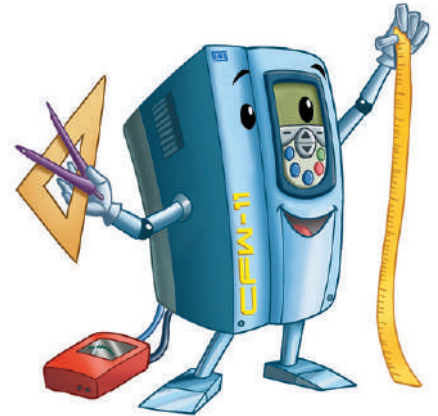

8.1 POWER DATA

Power Supply:

- Voltage tolerance: -15 % to +10 % of the nominal voltage.
- Frequency: 50/60 Hz (48 Hz to 62 Hz).
- Phase imbalance: $\leq 3\%$ of the rated phase-to-phase input voltage.
- Overvoltage according to Category III (EN 61010/UL 508C).
- Transient voltage according to Category III.
- Maximum of 60 connections per hour (1 per minute).
- Efficiency: according to class IE2 as per EN 50598-2.
- Typical input power factor:
 - 0.94 for models with three-phase input in the rated condition.
- $\cos \phi$ (displacement factor): > 0.98 .

Technical Specifications

Table 8.1 - Technical specifications of the CFW-11 inverter series frame size E models

Model		Models With 220...230 V Power Supply			Models With 380...480 V Power Supply				
		CFW11 0142 T 2	CFW11 0180 T 2	CFW11 0211 T 2	CFW11 0105 T 4	CFW11 0142 T 4	CFW11 0180 T 4	CFW11 0211 T 4	
Frame Size		E							
Number of Power Phases		3 ϕ							
Use With Normal Duty (ND) Cycle	Rated Output Current ⁽¹⁾ [Arms]	142	180	211	105	142	180	211	
	Overload Current ⁽²⁾ [Arms]	1 min	156.2	198.0	232	115.5	156.2	198.0	232.1
		3 s	213	270	317	157.5	213.0	270	317
	Rated Carrier Frequency [kHz]	2.5	2.5	2.5	2.5	2.5	2.5	2.5	
	Maximum Motor ⁽⁴⁾ [HP/kW]	50/37	60/45	75/55	75/55	100/75	150/110	175/132	
	Rated Input Current [Arms]	142.0	180.0	211.0	105.0	142.0	180.0	211.0	
	Dissipated Power [W]	Surface Mounting ⁽⁵⁾	1850	2200	2490	1650	2230	2660	3040
Flange Mounting ⁽⁶⁾		240	410	410	230	240	410	410	
Use With Heavy Duty (HD) Cycle	Rated Output Current ⁽¹⁾ [Arms]	115	142	180	88	115	142	180	
	Overload Current ⁽²⁾ [Arms]	1 min	172.5	213	270	132.0	172.5	213.0	270
		3 s	230	284	360	176.0	230.0	284	360
	Rated Carrier Frequency [kHz]	5 ⁽³⁾	5 ⁽³⁾	2.5	2.5	2.5	2.5	2.5	
	Maximum Motor ⁽⁴⁾ [HP/kW]	40/30	50/37	75/55	60/45	75/55	100/75	150/110	
	Rated Input Current [Arms]	115.0	142.0	180.0	88.0	115.0	142.0	180.0	
	Dissipated Power [W]	Surface Mounting ⁽⁵⁾	1700	2120	2240	1340	1710	2140	2530
Flange Mounting ⁽⁶⁾		230	390	400	220	230	390	400	
Surrounding Air Temperature [°C (°F)]		-10...45 °C (14...113 °F) (IP21/NEMA1) -10...40 °C (14...104 °F) (IP55)							
Dynamic Braking		Optional (the standard product does not have dynamic braking)							
RFI Filter		Built-in							
Weight [kg (lb)]		64.0 (141.1)	65.0 (143.3)	65.0 (143.3)	62.5 (137.8)	64.0 (141.1)	65.0 (143.3)	65.0 (143.3)	
Availability of Option Kits that Can be Incorporated Into the Product (refer to the intelligent code in Chapter 2 GENERAL INSTRUCTIONS on page 2-1) ⁽⁷⁾	Cabinet Enclosure	Yes, NEMA1 (separated kit KN1E-01); IP55	Yes, NEMA1 (separated kit KN1E-02); IP55		Yes, NEMA1 (separated kit KN1E-01); IP55		Yes, NEMA1 (separated kit KN1E-02); IP55		
	Dynamic Braking	Yes							
	Safety Stop	Yes							
	24 Vdc External Control Power Supply	Yes							

The notes for Table 8.1 on page 8-2 to Table 8.5 on page 8-4 are located after the Table 8.5 on page 8-4.

Table 8.2 - Specifications of the CFW-11 series frame size E models for a switching frequency of 5 kHz and Ta = 45 °C (*)

Model	Frame Size	Number of Power Phases	Use with Normal Duty (ND) Cycle						Use with Heavy Duty (HD) cycle								
			Rated Output Current ⁽¹⁾ [Arms]	Overload Current ⁽²⁾ [Arms]		Maximum Motor ⁽⁴⁾ [HP/kW]	Rated Input Current [Arms]	Dissipated Power [W]		Rated Output Current ⁽¹⁾ [Arms]	Overload Current ⁽²⁾ [Arms]		Maximum Motor ⁽⁴⁾ [HP/kW]	Rated Input Current [Arms]	Dissipated Power [W]		
				1 min	3 s			Surface Mounting ⁽⁵⁾	Flange Mounting ⁽⁶⁾		1 min	3 s			Surface Mounting ⁽⁵⁾	Flange Mounting ⁽⁶⁾	
Models with 220...230 V power supply	E	3φ	CFW11 0142 T 2	125.0	137.5	187.5	50/37	125.0	1880	230	102.0	153.0	204.0	40/30	102.0	1470	220
			CFW11 0180 T 2	159.0	174.9	239	60/45	159.0	2280	400	125.0	187.5	250	50/37	125.0	1760	390
			CFW11 0211 T 2	186.0	204.6	279	75/55	186.0	2600	400	159.0	239	318	60/45	159.0	2190	390
Models with 380...480 V power supply	E	3φ	CFW11 0105 T 4	82.0	90.2	123.0	60/45	82.0	1480	210	69.0	103.5	138.0	50/37	69.0	1240	210
			CFW11 0142 T 4	111.0	122.1	166.5	75/55	111.0	1980	220	90.0	135.0	180.0	75/55	90.0	1580	210
			CFW11 0180 T 4	140.0	154.0	210.0	100/75	140.0	2410	390	111.0	166.5	222.0	75/55	111.0	1920	380
			CFW11 0211 T 4	164.0	180.4	246.0	125/90	164.0	2810	390	140.0	210.0	280.0	125/90	140.0	2400	380

The notes for Table 8.1 on page 8-2 to Table 8.5 on page 8-4 are located after the Table 8.5 on page 8-4.

(*) For models with optional IP55 must be consulted to WEG.

Table 8.3 - Specifications of the CFW-11 series frame size E models for a switching frequency of 5 kHz and Ta = 40 °C (*)

Model	Frame Size	Number of Power Phases	Use with Normal Duty (ND) Cycle						Use with Heavy Duty (HD) cycle								
			Rated Output Current ⁽¹⁾ [Arms]	Overload Current ⁽²⁾ [Arms]		Maximum Motor ⁽⁴⁾ [HP/kW]	Rated Input Current [Arms]	Dissipated Power [W]		Rated Output Current ⁽¹⁾ [Arms]	Overload Current ⁽²⁾ [Arms]		Maximum Motor ⁽⁴⁾ [HP/kW]	Rated Input Current [Arms]	Dissipated Power [W]		
				1 min	3 s			Surface Mounting ⁽⁵⁾	Flange Mounting ⁽⁶⁾		1 min	3 s			Surface Mounting ⁽⁵⁾	Flange Mounting ⁽⁶⁾	
Models with 220...230 V power supply	E	3φ	CFW11 0142 T 2	132.0	145.2	198.0	50/37	132.0	2010	230	108.0	162.0	216.0	40/30	108.0	1570	220
			CFW11 0180 T 2	168.0	184.8	252	60/45	168.0	2430	410	132.0	198.0	264	50/37	132.0	1860	390
			CFW11 0211 T 2	196.0	216	294	75/55	196.0	2760	410	168.0	252	336	60/45	168.0	2320	390
Models with 380...480 V power supply	E	3φ	CFW11 0105 T 4	87.0	95.7	130.5	75/55	87.0	1590	220	73.0	109.5	146.0	60/45	73.0	1310	210
			CFW11 0142 T 4	117.0	128.7	175.5	100/75	117.0	2100	230	95.0	142.5	190.0	75/55	95.0	1670	220
			CFW11 0180 T 4	148.0	162.8	222.0	125/90	148.0	2560	400	117.0	175.5	234.0	100/75	117.0	2020	380
			CFW11 0211 T 4	173.0	190.3	259.5	150/110	173.0	2970	400	148.0	222.0	296.0	125/90	148.0	2540	390

The notes for Table 8.1 on page 8-2 to Table 8.5 on page 8-4 are located after the Table 8.5 on page 8-4.

(*) For models with optional IP55 must be consulted to WEG.

Table 8.4 - Specifications of the CFW-11 series frame size E models for a switching frequency of 10 kHz and Ta = 45 °C (*)

Model	Frame Size	Number of Power Phases	Use with Normal Duty (ND) Cycle							Use with Heavy Duty (HD) cycle							
			Rated Output Current ⁽¹⁾ [Arms]	Overload Current ⁽²⁾ [Arms]		Maximum Motor ⁽⁴⁾ [HP/kW]	Rated Input Current [Arms]	Dissipated Power [W]		Rated Output Current ⁽¹⁾ [Arms]	Overload Current ⁽²⁾ [Arms]		Maximum Motor ⁽⁴⁾ [HP/kW]	Rated Input Current [Arms]	Dissipated Power [W]		
				1 min	3 s			Surface Mounting ⁽⁵⁾	Flange Mounting ⁽⁶⁾		1 min	3 s			Surface Mounting ⁽⁵⁾	Flange Mounting ⁽⁶⁾	
Models with 220...230 V power supply	E	3φ	CFW11 0142 T 2	100.0	110.0	150.0	40/30	100.0	1740	220	81.0	121.5	162.0	30/22	81.0	1390	210
			CFW11 0180 T 2	126.0	138.6	189	50/37	126.0	2140	390	100.0	150.0	200	40/30	100.0	1720	370
			CFW11 0211 T 2	148.0	162.8	222	60/45	148.0	2500	390	126.0	189	252	50/37	126.0	2140	380
Models with 380...480 V power supply	E	3φ	CFW11 0105 T 4	58.0	63.8	87.0	50/37	58.0	1430	200	49.0	73.5	98.0	40/30	49.0	1240	200
			CFW11 0142 T 4	79.0	86.9	118.5	60/45	79.0	1910	210	64.0	96.0	128.0	50/37	64.0	1580	200
			CFW11 0180 T 4	99.0	108.9	148.5	75/55	99.0	2380	370	79.0	118.5	158.0	60/45	79.0	1980	360
			CFW11 0211 T 4	117.0	128.7	175.5	100/75	117.0	2860	370	99.0	148.5	198.0	75/55	99.0	2510	370

The notes for Table 8.1 on page 8-2 to Table 8.5 on page 8-4 are located after the Table 8.5 on page 8-4.

(*) For models with optional IP55 must be consulted to WEG.

Table 8.5 - Specifications of the CFW-11 series frame size E models for a switching frequency of 10 kHz and Ta = 40 °C (*)

Model	Frame Size	Number of Power Phases	Use with Normal Duty (ND) Cycle							Use with Heavy Duty (HD) cycle							
			Rated Output Current ⁽⁸⁾ [Arms]	Overload Current ⁽²⁾ [Arms]		Maximum Motor ⁽⁴⁾ [HP/kW]	Rated Input Current [Arms]	Dissipated Power [W]		Rated Output Current ⁽⁸⁾ [Arms]	Overload Current ⁽²⁾ [Arms]		Maximum Motor ⁽⁴⁾ [HP/kW]	Rated Input Current [Arms]	Dissipated Power [W]		
				1 min	3 s			Surface Mounting ⁽⁵⁾	Flange Mounting ⁽⁶⁾		1 min	3 s			Surface Mounting ⁽⁵⁾	Flange Mounting ⁽⁶⁾	
Models with 220...230 V power supply	E	3φ	CFW11 0142 T 2	106.0	116.6	159.0	40/30	106.0	1850	220	86.0	129.0	172.0	30/22	86.0	1480	210
			CFW11 0180 T 2	133.0	146.3	200	50/37	133.0	2260	390	106.0	159.0	212	40/30	106.0	1810	380
			CFW11 0211 T 2	156.0	172	234	60/45	156.0	2630	390	133.0	200	266	50/37	133.0	2250	380
Models with 380...480 V power supply	E	3φ	CFW11 0105 T 4	62.0	68.2	93.0	50/37	62.0	1530	200	52.0	78.0	104.0	40/30	52.0	1300	200
			CFW11 0142 T 4	84.0	92.4	126.0	60/45	84.0	2020	210	68.0	102.0	136.0	50/37	68.0	1670	200
			CFW11 0180 T 4	105.0	115.5	157.5	75/55	105.0	2500	380	84.0	126.0	168.0	60/45	84.0	2080	370
			CFW11 0211 T 4	124.0	136.4	186.0	100/75	124.0	3000	380	105.0	157.5	210.0	75/55	105.0	2620	370

(*) For models with optional IP55 must be consulted to WEG.

(1) Rated current in permanent duty under the following conditions:

- Recommended switching frequencies. For operation with higher switching frequencies, it is necessary to reduce the rated output current according to Table 8.2 on page 8-3 and Table 8.5 on page 8-4.
- Ambient temperature around the inverter: -10 °C to 45 °C (14 °F to 113 °F). The inverter may operate in environments with ambient temperatures around the inverter up to 55 °C (131 °F) if a derating of 2 % is applied to the output current for each °C above 45 °C (113 °F). Such current derating is valid for all switching frequencies.
- Inverters CFW-11 with IP55 degree protection: -10 °C to 40 °C (14 °F to 104 °F) - standard conditions (surrounding the inverter).
- Inverters CFW-11 with IP55 degree protection: 40 °C to 50 °C (104 °F to 122 °F) - current derating of 2 % for each degree Celsius above 40 °C (104 °F).
- Air relative humidity: 5 % to 95 % non-condensing.
- From 1000 m to 4000 m (3,300 ft to 13,200 ft) – apply current derating of 1 % for each 100 m above 1000 m of altitude.
- From 2000 m to 4000 m (6,600 ft to 13,200 ft) - apply maximum voltage derating (240 V for models 220...240 V, and 480 V for models 380...480 V) of 1.1 % for each 100 m (328 ft) above 2000 m (6,600 ft).
- Environment with pollution degree 2 (as per EN50178 and UL 508C).

- (2) Table 8.1 on page 8-2 presents only two points of the overload curve (actuation time of 1 min and 3 s). The complete overload curves of the IGBTs for ND and HD are presented below. Depending on the inverter operating conditions (ambient temperature around the inverter, output frequency, possibility or not of switching frequency derating, etc.), the maximum operating time of the inverter with overload may be shortened.
- (3) The switching frequency may be automatically reduced to 2.5 kHz, depending on the operating conditions (ambient temperature around the inverter, output current, etc.) - if P0350 = 0 or 1. If necessary to operate always at 5 kHz, set P0350 = 2 or 3, and consider the rated current values of Table 8.2 on page 8-3 and Table 8.3 on page 8-3. Note that, in this case, it is necessary to apply a current derating to the inverter rated output current.
- (4) The motor outputs are only for guiding purposes for WEG motors of 230 V or 460 V with 4 poles. The proper sizing must be done according to the rated current of the motors used.
- (5) The specified losses are valid for the nominal operating conditions, that is, for the rated output current and switching frequency.
- (6) The dissipated power for flange mounting corresponds to the total losses of the inverter minus the losses on the power modules (IGBT and rectifier).
- (7) In order to indicate that the inverter should come with such optional item, it is necessary to specify it in the inverter smart code.
- (8) Ambient temperature around the inverter: -10 to 40 °C (14 °F to 104 °F). The inverter may operate in environments with ambient temperatures around the inverter up to 55 °C (131 °F) if a derating of 2 % is applied to the output current for each °C above 40 °C (104 °F).
 - Air relative humidity: 5 % to 90 % non-condensing.
 - From 1000 m to 4000 m (3,300 ft to 13,200 ft) – apply current derating of 1 % for each 100 m above 1000 m of altitude.
 - From 2000 m to 4000 m (6,600 ft to 13,200 ft) - apply maximum voltage derating (240 V for models 220...240 V, and 480 V for models 380...480 V) of 1.1 % for each 100 m (328 ft) above 2000 m (6,600 ft).
 - Environment with pollution degree 2 (as per EN50178 and UL 508C).

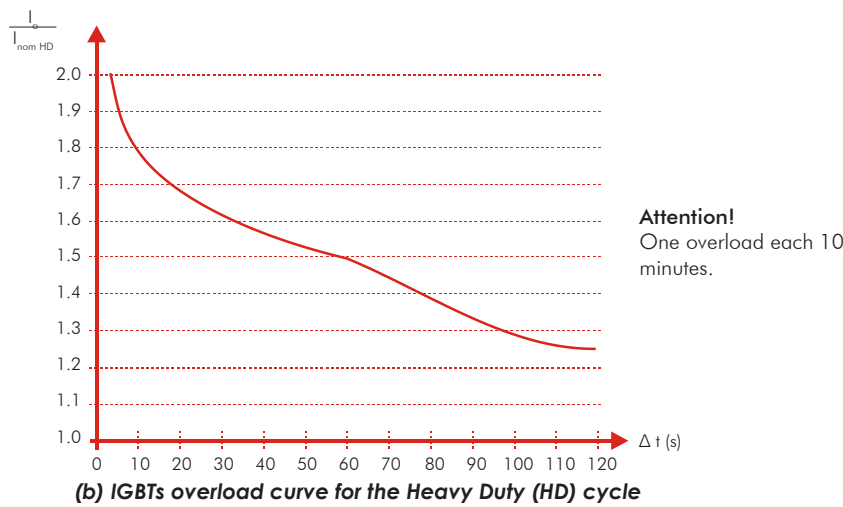
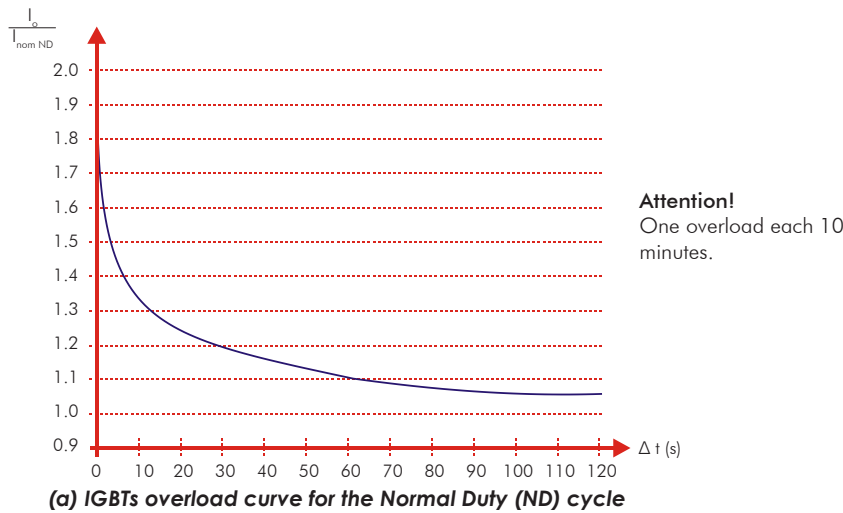

Figure 8.1 - (a) and (b) - IGBT overload curves for ND and HD use

8.2 ELECTRICAL/GENERAL SPECIFICATIONS

Control	Method	<ul style="list-style-type: none"> <input checked="" type="checkbox"/> Voltage source <input checked="" type="checkbox"/> Type of control: <ul style="list-style-type: none"> - V/f (Scalar) - VVW: Voltage Vector Control - Vector control with encoder - Sensorless vector control (without encoder) <input checked="" type="checkbox"/> PWM SVM (Space Vector Modulation) <input checked="" type="checkbox"/> Full digital (software) current, flux, and speed regulators Execution rate: <ul style="list-style-type: none"> - current regulators: 0.2 ms (5 kHz) - flux regulator: 0.4 ms (2.5 kHz) - speed regulator/speed measurement: 1.2 ms
	Output Frequency	<ul style="list-style-type: none"> <input checked="" type="checkbox"/> 0 to 3.4 x rated motor frequency (P0403). The rated frequency is programmable from 0 Hz to 300 Hz in the scalar mode and from 30 Hz to 120 Hz in the vector mode <input checked="" type="checkbox"/> Output frequency limits as a function of the switching frequency: <ul style="list-style-type: none"> - 125 Hz (switching frequency = 1.25 kHz) - 200 Hz (switching frequency = 2 kHz) - 250 Hz (switching frequency = 2.5 kHz) - 500 Hz (switching frequency = 5 kHz) - 1000 Hz (switching frequency = 10 kHz)
Performance	Speed Control	<p><u>V/f (Scalar):</u></p> <ul style="list-style-type: none"> <input checked="" type="checkbox"/> Regulation (with slip compensation): 1 % of the rated speed <input checked="" type="checkbox"/> Speed variation range: 1:20 <p><u>VVW:</u></p> <ul style="list-style-type: none"> <input checked="" type="checkbox"/> Regulation: 1 % of the rated speed <input checked="" type="checkbox"/> Speed variation range: 1:30 <p><u>Sensorless:</u></p> <ul style="list-style-type: none"> <input checked="" type="checkbox"/> Regulation: 0.5 % of the rated speed <input checked="" type="checkbox"/> Speed variation range: 1:100 <p><u>Vector with Encoder (P0202 = 4 induction motor or P0202 = 6 permanent magnet):</u></p> <ul style="list-style-type: none"> <input checked="" type="checkbox"/> Regulation: <ul style="list-style-type: none"> ±0.01 % of the rated speed with a 14-bits analog input (IOA); ±0.01 % of the rated speed with a digital reference (Keypad, Serial, Fieldbus, Electronic Potentiometer, Multispeed) ±0.05 % of the rated speed with a 12-bits analog input (CC11) <input checked="" type="checkbox"/> Speed variation range: 1:1000
	Torque Control	<ul style="list-style-type: none"> <input checked="" type="checkbox"/> Range: 10 to 180 %, regulation: ±5 % of the rated torque (P0202 = 4, 6 or 7) <input checked="" type="checkbox"/> Range: 20 to 180 %, regulation: ±10 % of the rated torque (P0202 = 3, above 3 Hz)
Inputs (CC11 Board)	Analog	<ul style="list-style-type: none"> <input checked="" type="checkbox"/> 2 isolated differential inputs; resolution of AI1: 12 bits, resolution of AI2: 11bits + signal, (0 to 10) V, (0 to 20) mA or (4 to 20) mA, impedance: 400 kΩ for (0 to 10) V, 500 Ω for (0 to 20) mA or (4 to 20) mA, programmable functions
	Digital	<ul style="list-style-type: none"> <input checked="" type="checkbox"/> 6 isolated digital inputs, 24 Vdc, programmable functions
Outputs (CC11 Board)	Analog	<ul style="list-style-type: none"> <input checked="" type="checkbox"/> 2 isolated analog outputs, (0 to 10) V, $R_L \geq 10 \text{ k}\Omega$ (maximum load), 0 to 20 mA / 4 to 20 mA ($R_L \leq 500 \text{ }\Omega$) resolution: 11 bits, programmable functions
	Relay	<ul style="list-style-type: none"> <input checked="" type="checkbox"/> 3 relay outputs with NO/NC contacts, 240 Vac, 1 A, programmable functions
Safety	Protection	<ul style="list-style-type: none"> <input checked="" type="checkbox"/> Output overcurrent/short-circuit <input checked="" type="checkbox"/> Under/Overvoltage <input checked="" type="checkbox"/> Phase loss <input checked="" type="checkbox"/> Overtemperature <input checked="" type="checkbox"/> Braking resistor overload <input checked="" type="checkbox"/> IGBTs overload <input checked="" type="checkbox"/> Motor overload <input checked="" type="checkbox"/> External fault/alarm <input checked="" type="checkbox"/> CPU or memory fault <input checked="" type="checkbox"/> Output phase-ground short-circuit

Integral Keypad (HMI)	Standard Keypad	<ul style="list-style-type: none"> <input checked="" type="checkbox"/> 9 operator keys: Start/Stop, Up arrow, Down arrow, Direction of rotation, Jog, Local/Remote, Right soft key and Left soft key <input checked="" type="checkbox"/> Graphical LCD display <input checked="" type="checkbox"/> View/edition of parameters <input checked="" type="checkbox"/> Indication accuracy: <ul style="list-style-type: none"> - current: 5 % of the rated current - DC Link voltage: 3 % - speed resolution: 1 rpm <input checked="" type="checkbox"/> Possibility of remote mounting
Enclosure	IP20	<input checked="" type="checkbox"/> Standard
	IP21	<input checked="" type="checkbox"/> Inverters with kit IP21
	Nema1	<input checked="" type="checkbox"/> Inverters with Nema1 kit (KN1E-01 or KN1E-02)
	IP54	<input checked="" type="checkbox"/> Inverter back part (external part for flange mounting) – for models 180T2, 211T2, 180T4 and 211T4 need special hardware H1
	IP55	<input checked="" type="checkbox"/> Inverters with optional IP55 (CFW11 ...T...O55...)
PC Connection for Inverter Programming	USB Connector	<ul style="list-style-type: none"> <input checked="" type="checkbox"/> USB standard Rev. 2.0 (basic speed) <input checked="" type="checkbox"/> Type B (device) USB plug <input checked="" type="checkbox"/> Interconnection cable: standard host/device shielded USB cable

8.3 CODES AND STANDARDS

Safety Standards	<ul style="list-style-type: none"> <input checked="" type="checkbox"/> UL 508C - Power conversion equipment Note: Suitable for Installation in a compartment handling conditioned air <input checked="" type="checkbox"/> UL 840 - Insulation coordination including clearances and creepage distances for electrical equipment <input checked="" type="checkbox"/> EN61800-5-1 - Safety requirements electrical, thermal and energy <input checked="" type="checkbox"/> EN 50178 - Electronic equipment for use in power installations <input checked="" type="checkbox"/> EN 60204-1 - Safety of machinery. Electrical equipment of machines. Part 1: general requirements Note: The final assembler of the machine is responsible for installing an safety stop device and a supply disconnecting device <input checked="" type="checkbox"/> EN 60146 (IEC 146) - Semiconductor converters <input checked="" type="checkbox"/> EN 61800-2 - Adjustable speed electrical power drive systems - Part 2: general requirements - Rating specifications for low voltage adjustable frequency AC power drive systems
Electromagnetic Compatibility (EMC)	<ul style="list-style-type: none"> <input checked="" type="checkbox"/> EN 61800-3 - Adjustable speed electrical power drive systems - Part 3: EMC product standard including specific test methods. <input checked="" type="checkbox"/> EN 61000-4-2 - Electromagnetic compatibility (EMC) - Part 4: testing and measurement techniques - Section 2: Electrostatic discharge immunity test <input checked="" type="checkbox"/> EN 61000-4-3 - Electromagnetic compatibility (EMC) - Part 4: testing and measurement techniques - Section 3: Radiated, radio-frequency, electromagnetic field immunity test <input checked="" type="checkbox"/> EN 61000-4-4 - Electromagnetic compatibility (EMC) - Part 4: testing and measurement techniques - Section 4: Electrical fast transient/burst immunity test <input checked="" type="checkbox"/> EN 61000-4-5 - Electromagnetic compatibility (EMC) - Part 4: testing and measurement techniques - Section 5: Surge immunity test <input checked="" type="checkbox"/> EN 61000-4-6 - Electromagnetic compatibility (EMC)- Part 4: testing and measurement techniques - Section 6: Immunity to conducted disturbances, induced by radio-frequency fields <input checked="" type="checkbox"/> EN 61000-4-11 - Testing and measurement techniques - voltage dips, short interruptions and voltage variations immunity tests
Mechanical Standards	<ul style="list-style-type: none"> <input checked="" type="checkbox"/> EN 60529 - Degrees of protection provided by enclosures (IP code) <input checked="" type="checkbox"/> UL 50 - Enclosures for electrical equipment <input checked="" type="checkbox"/> EC60721-3-3 - Classification of environmental conditions - part 3: classification of groups of environmental parameters and their severities - section 3: stationary use at weather protected locations Level 3M4

8.4 CERTIFICATIONS

Certifications (*)	Notes
UL and cUL	E184430
CE	
IRAM	
C-Tick	
EAC	
ABS	Link: http://ww2.eagle.org/en/rules-and-resources/type-approval-database.html After accessing the link, click on "Select Option" and select "Data Search" On the new window, the certificate number must be entered on the "Certificate Number" field: 15-RJ2890495. Click on "Search"
Functional Safety	STO Funtion, with certificate issued by TÜV Rheinland

(*) For updated information on certifications, please contact WEG.

8.5 MECHANICAL DATA

IP20

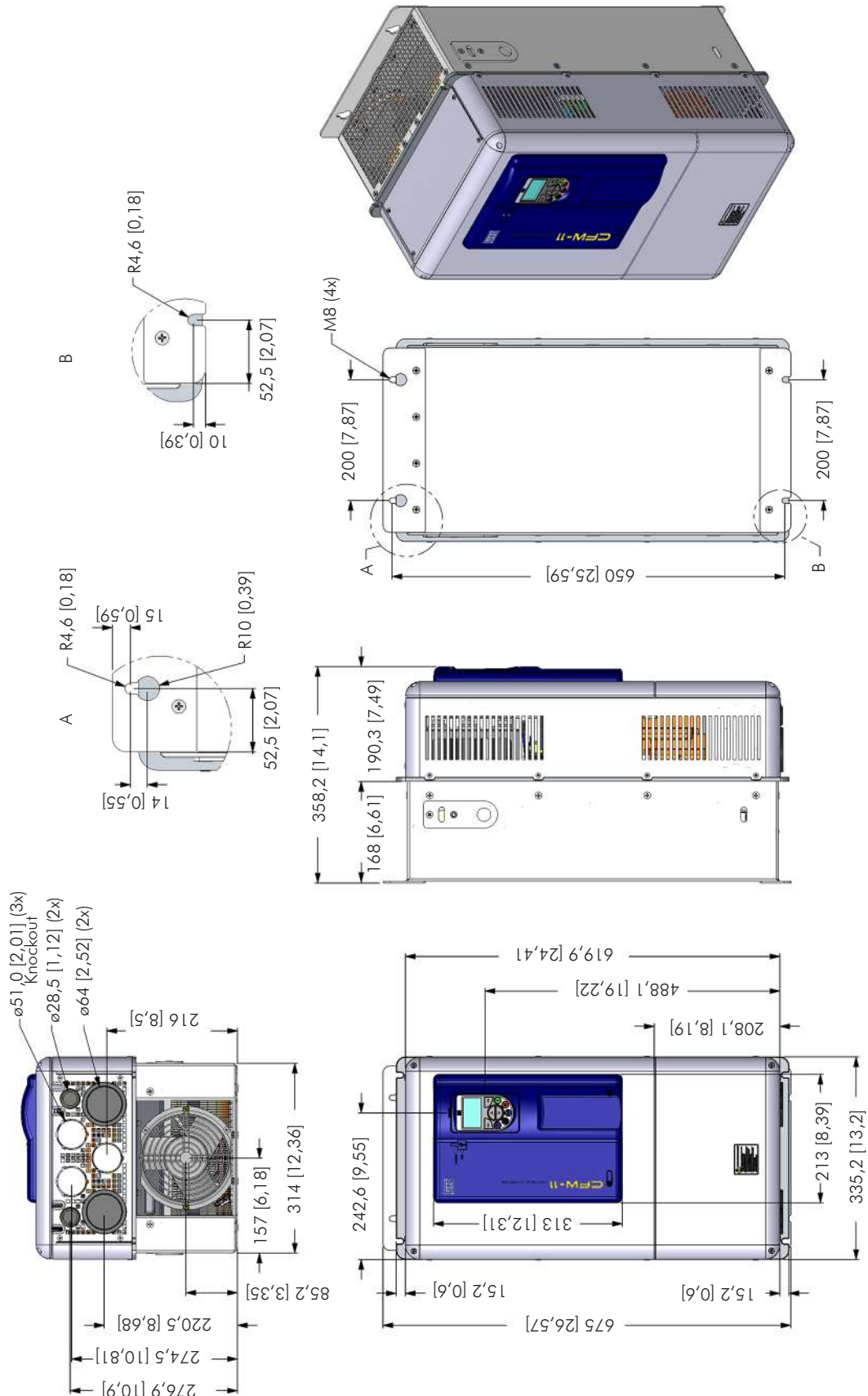

Figure 8.2 - Inverter dimensions - frame size E - mm [in]

IP55

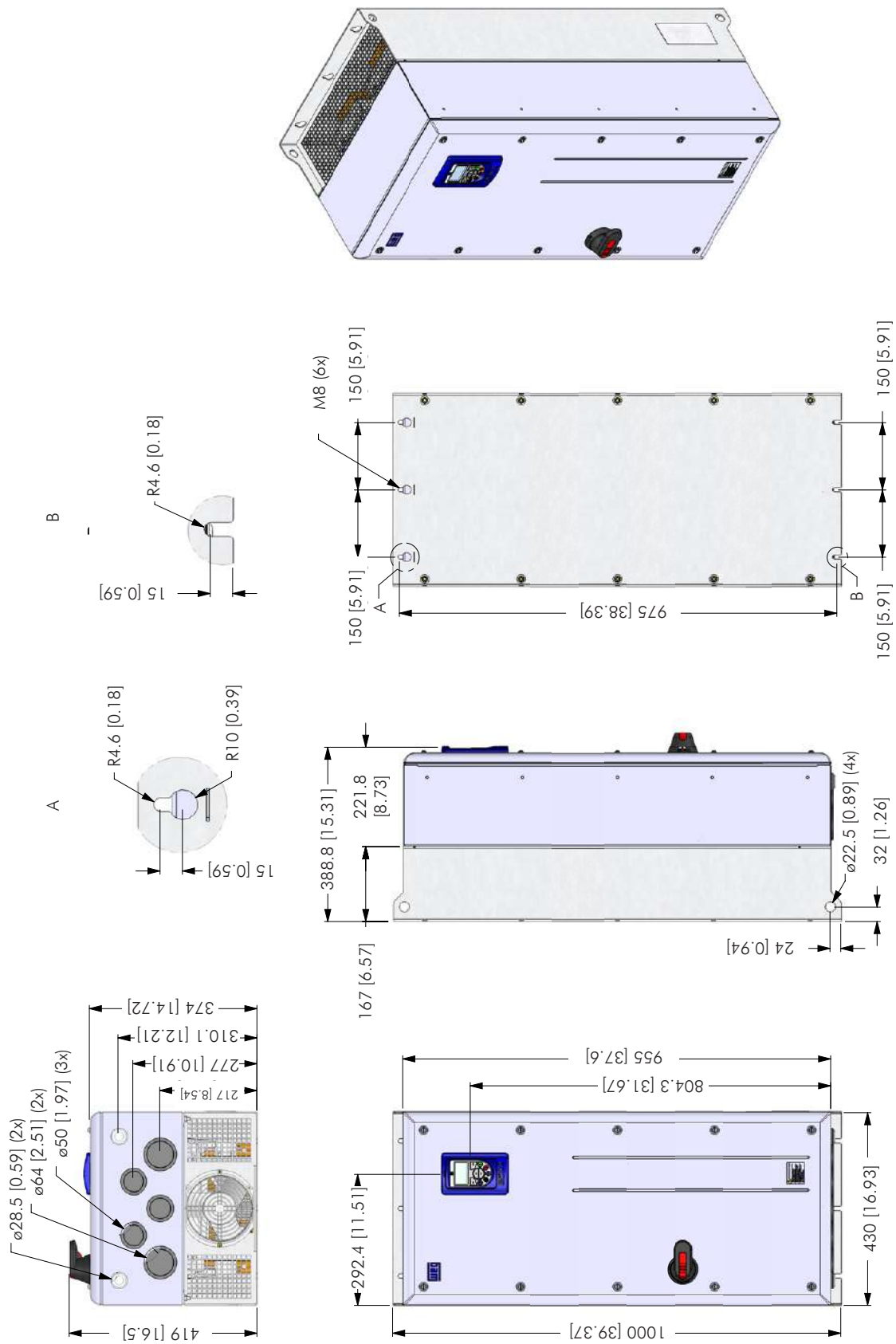

Figure 8.3 - Inverter dimensions - for models with optional IP55 - frame size E - mm [in]

8.6 NEMA1 KIT



- Weight of the KN1E-01 kit: 2.12 kg (4.67 lb)

(a) Frame size E with the Nema1 kit KN1E-01 - CFW11 0142 T 2 O N1, CFW11 0105 T 4 O N1 and CFW11 0142 T 4 O N1 models

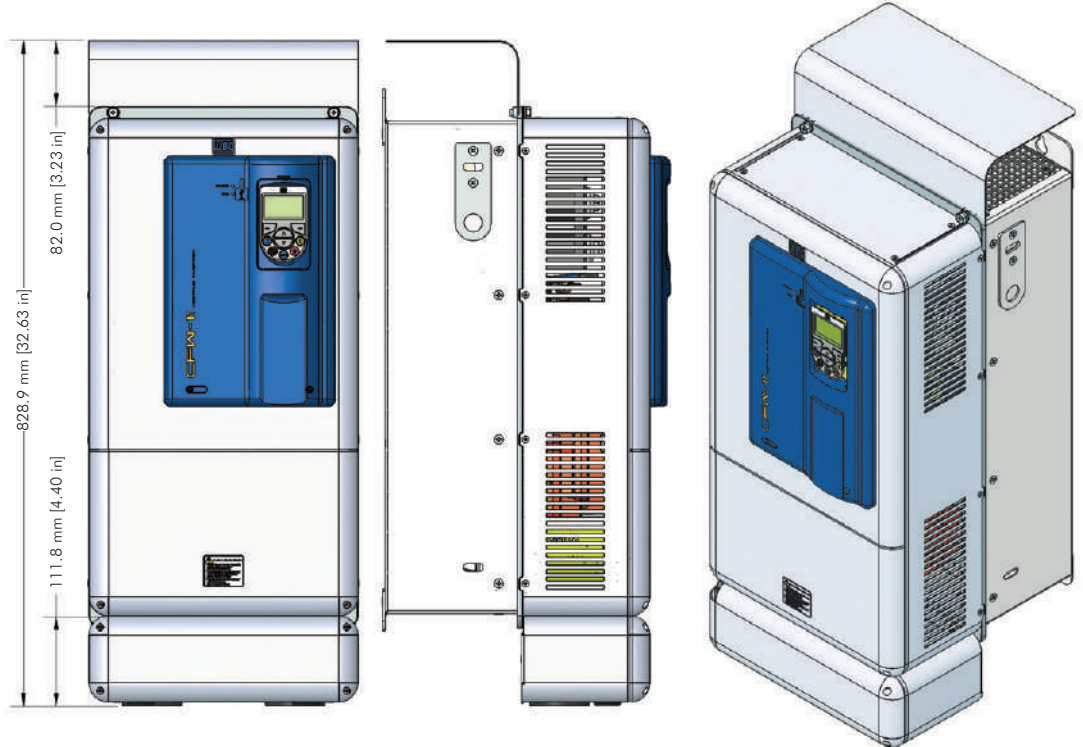

- Weight of the KN1E-02 kit: 4.3 kg (9.48 lb)

(b) Frame size E with the Nema1 kit KN1E-02 - CFW11 0180 T 2 O N1, CFW11 0211 T 2 O N1, CFW11 0180 T 4 O N1 and CFW11 0211 T 4 O N1 models

Figure 8.4 - (a) and (b) - Inverter with the Nema1 kit